



Donaldson.
FILTRATION SOLUTIONS

Installation and Operation Manual

Installation, Operation and Maintenance Manual

HV150, HV300, HV600, HV1000

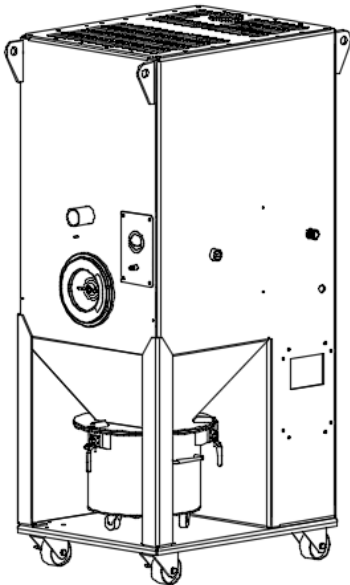

HV150/300

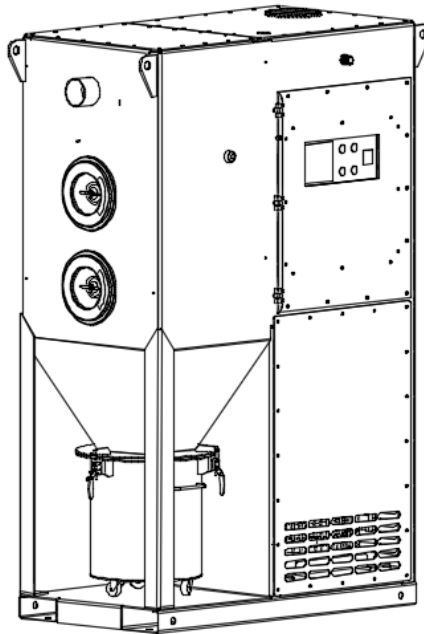

HV600

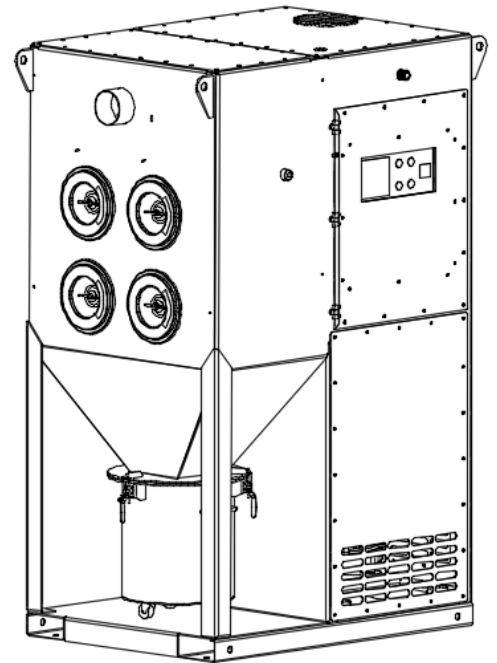

HV1000



Throughout this manual statements indicating precautions necessary *to avoid equipment failure* are referenced in a **Note**. Statements indicating potential hazards that could result in *personal injury or property damage* are referenced in a **CAUTION!** box.

Donaldson Company reserves the right to change design and specifications without prior notice.

Illustrations are for reference only as actual product may vary.

IOM AK0303201
Revision 0



CAUTION!

Application of Dust Control Equipment

- Combustible materials such as buffing lint, paper, wood, aluminum or steel dust, weld fume, or flammable solvents represent fire or explosion hazards. Use special care when selecting and operating all dust or fume collection equipment when combustible materials are present to protect workers and property from damage due to fire and/or explosion. Consult and comply with National and Local Codes relating to fire or explosion and all other appropriate codes when determining the location and operation of dust or fume collection equipment.
- When combustible materials are present, consult with an installer of fire extinguishing systems familiar with these types of fire hazards and local fire codes for recommendations and installation of fire extinguishing and explosion protection systems. Donaldson Torit dust collection equipment is not equipped with fire extinguishing or explosion protection systems.
- DO NOT allow sparks, cigarettes or other burning objects to enter the hood or duct of any dust or fume control equipment as these may initiate a fire or explosion.
- For optimum collector performance, use only Donaldson Torit replacement parts.

Warning – Improper operation of a dust control system may contribute to conditions in the work area or facility that could result in severe personal injury and product or property damage. Check that all collection equipment is properly selected and sized for the intended use.

Table of contents

1.0 Product Introduction 6

2.0 Installation 6

3.0 Start up and Operation 7

4.0 Service 8

5.0 Optional equipment..... 9

6.0 Trouble Shooting 9

7.0 Control Panel 12

8.0 Spare Parts 22

List of figures

Figure 1: Schematic

Figure 2: Operational Schematic

Figure 3: Inlet Schematic

Figure 4: Fan Rotation Check Schematic

Figure 5: Dust Disposal System

Figure 6: Exchanging Filter Element

Figure 7: BIBO Module

Figure 8: HV150/300 Control Panel

Figure 9: HV150/300 Wiring Diagram

Figure 10: HV150/300 BIBO Control Panel

Figure 11: HV150/300 BIBO Electrical Terminal Block

Figure 12: HV150/300 BIBO Wiring Diagram

Figure 13: HV600/1000(BIBO) Control Panel

Figure 14: HV1000 BIBO Electrical Terminal Block

Figure 15: HV1000 BIBO Wiring Diagram



This manual contains specific precautionary statements relative to worker safety. Read thoroughly and comply as directed. Discuss the use and application of this equipment with a Donaldson Torit representative. Instruct all personnel on safe use and maintenance procedures.

Data Sheet

Model Number _____ Serial Number _____

Ship Date _____ Installation Date _____

Customer Name _____

Address _____

Filter Type _____

Accessories _____

Other _____

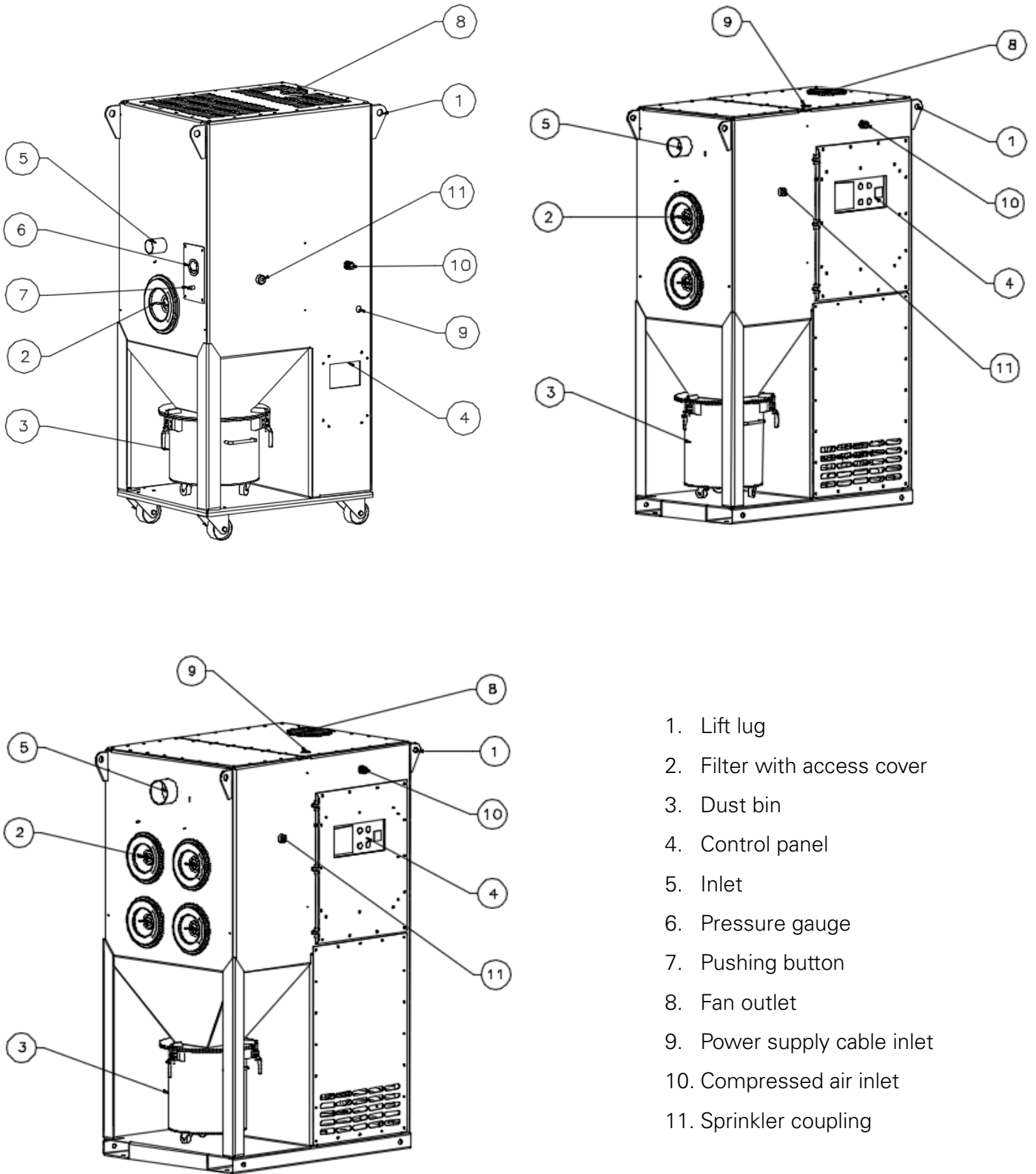
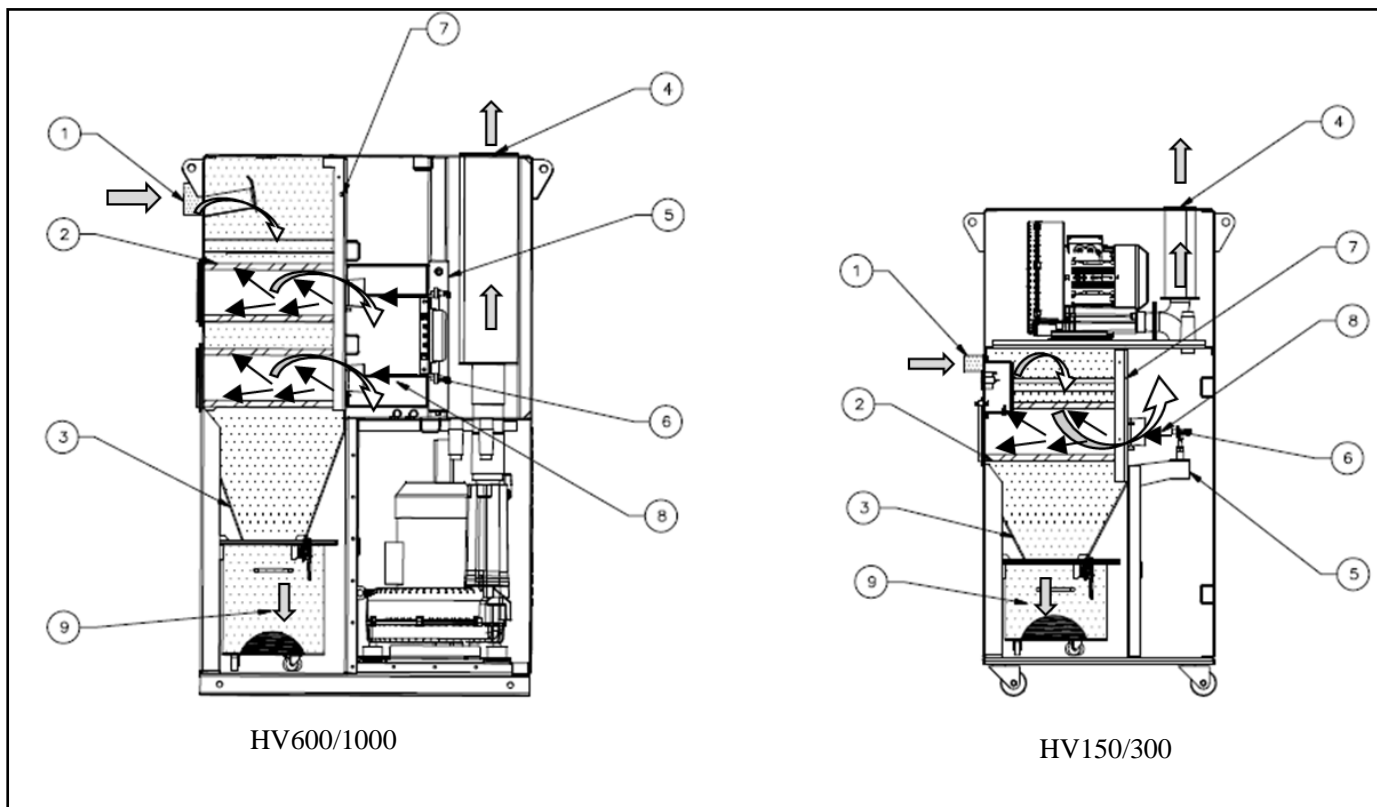

Figure 1
Schematic



Operation		Filter element cleaning	
1. Dirty air inlet	4. Clean air outlet	7. Tube sheet	
2. Filter element	5. Manifold	8. Air pulse	
3. Hopper	6. Diaphragm valve	9. Dust (falling)	

Figure 2
Operational Schematic

1.0 Product Introduction

The dust collector is used for the collection of airborne dust and particulate. Whether in answer to the problem of air pollution, or as part of a manufacturing process, the dust collector provides highly efficient and continuous on-line dust collection.

The filter elements are the heart of the dust collector. These filter elements help ensure the only cleaned air is returned to the plant environment.

During operation, contaminated air enters the dust collector through the dirty air inlet area and passes through the filter elements. Dust is collected on the surface of the filter elements. The filtered air flows through the centre of the filter elements into the clean air chamber, where it exhausts through the clean air outlet re-circulated into the environment.

To ensure the optimal performance of your dust collector it is necessary that the filter elements are cleaned automatically sequentially (HV600 and HV1000), and the filter is cleaned manually by pressing the push button (HV150 and HV300). During the filter sequence, the corresponding diaphragm valve will send a pulse of compressed air through the filter elements (from the inside outwards), removing the collected dust from the outside surface of the filter elements. The dust falls through the hopper into the dust disposal system.

2.0 Installation

Ensure all persons carrying out work on the supplied equipment follow any relevant recognized standards or codes and are competent to do so.

2.1 Compressed Air Connection

Compressed air pressure must be at 6 bar.

Be sure that all compressed air components are adequately sized to meet the maximum system requirements of 5 Nliters per pulse at 6 bar supply pressure (= design pressure).

Compressed air supply has to be both oil and moisture free.

Connect the compressed air supply line to the compressed air connection of the dust collector and also for pneumatic butterfly Valve if dust collector is equipped with hopper BIBO Module.

A compressed air shut-off valve, a filter/water separator with automatic condense drain, a pressure regulator with gage must be installed on the compressed air supply line.

2.2 Electrical Connection

Enter the cable through the cable gland locate at the lower right corner (HV150 and HV300) or top right corner (HV600 and HV1000) of the collector. And enter the cable to the control box through the cable gland locate at the top of the enclosure. Please follow the electrical diagram provided for connection.

Do not install in classified hazardous atmospheres without an enclosure rated for the application.

2.3 Inlet Duct Connection

The inlet collar is shown on figure 3.

3.0 Start-up and Operation

Check that the outlet of the fan is free of debris before starting.

Make sure the dust disposal system is properly installed under the hopper.

Check if the access doors are closed.

Switch main power on and press switch 'start'.

Turn on the compressed air supply. Adjust to 6 bar of pressure with the compressed air regular.

Motor and fan should be wired for right rotation, see below Figure 4

To reverse rotation, three-phase power supply: Turn electrical power OFF at source and switch any two leads on the control box.

**High temperature air,
Please don't touch!**

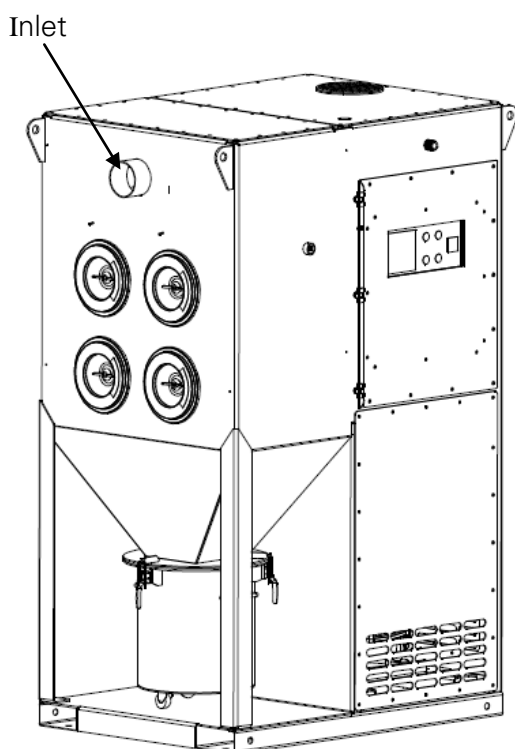

**Figure 3
Inlet Schematic**

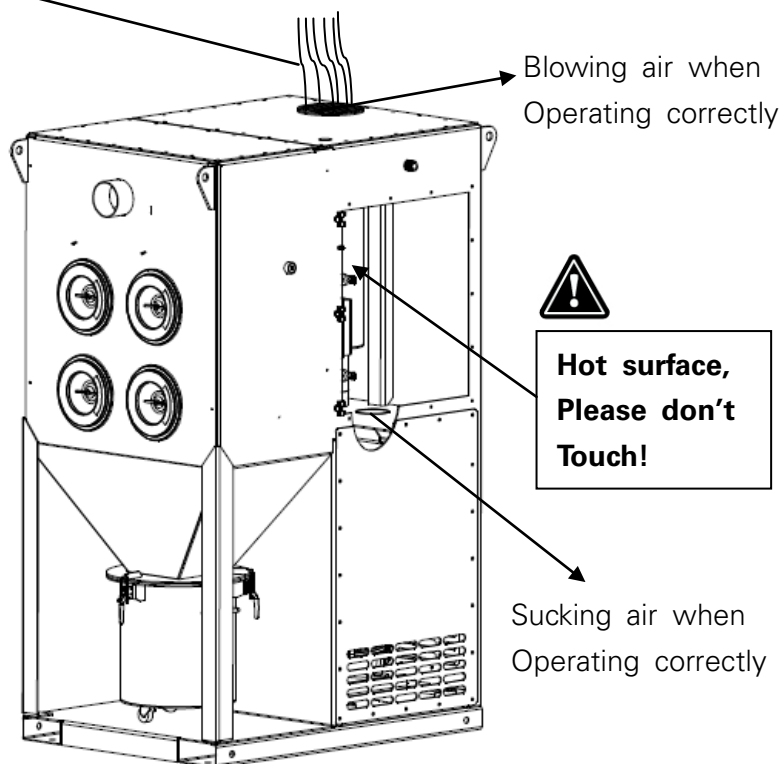

**Figure 4
Fan Rotation Check Schematic**

4.0 Service

Caution

Disconnect electrical power before servicing.

Shut off and bleed compressed air supply before servicing any compressed air components.

The filter elements are cleaned automatically and sequentially. Don't move out the filter elements and clean.

4.1 Dust Removal

Do not let the dustbin overfill. It can cause poor dust collector performance.

Turn off the dust collector and empty the dustbin on a regular base (recommend to empty the dustbin when 2/3 full).

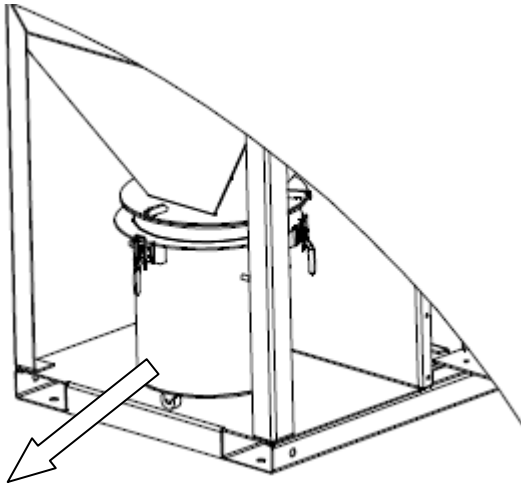

Move out
From this side

Figure 5
Dust Disposal System

4.2 Replacing of Filter Elements

Caution:

When the airflow is low or the differential pressure is too high and alarm, must change the filter elements.

All filters elements should be changed at the same time.

Do not drop the new filter element on the floor or any other hard surface. It is necessary to clean the dust of the tube sheet all around the opening to ensure a positive seal of the gasket.

Slide the new filter element along the yoke with the gasket end facing inward towards the clean air chamber.

Screw the wing nut clockwise onto the yoke. Tighten securely, to prevent leakage.

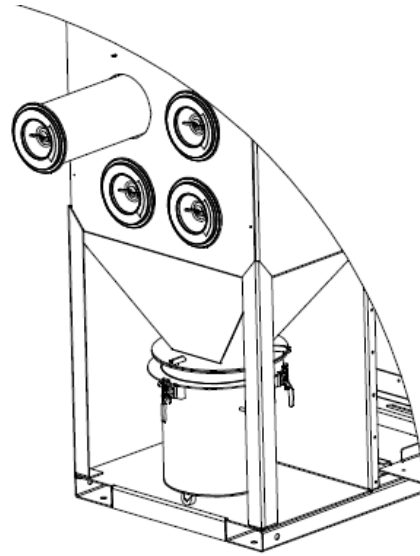

Figure 6
Replacing of Filter Elements

5.0 Optional equipment

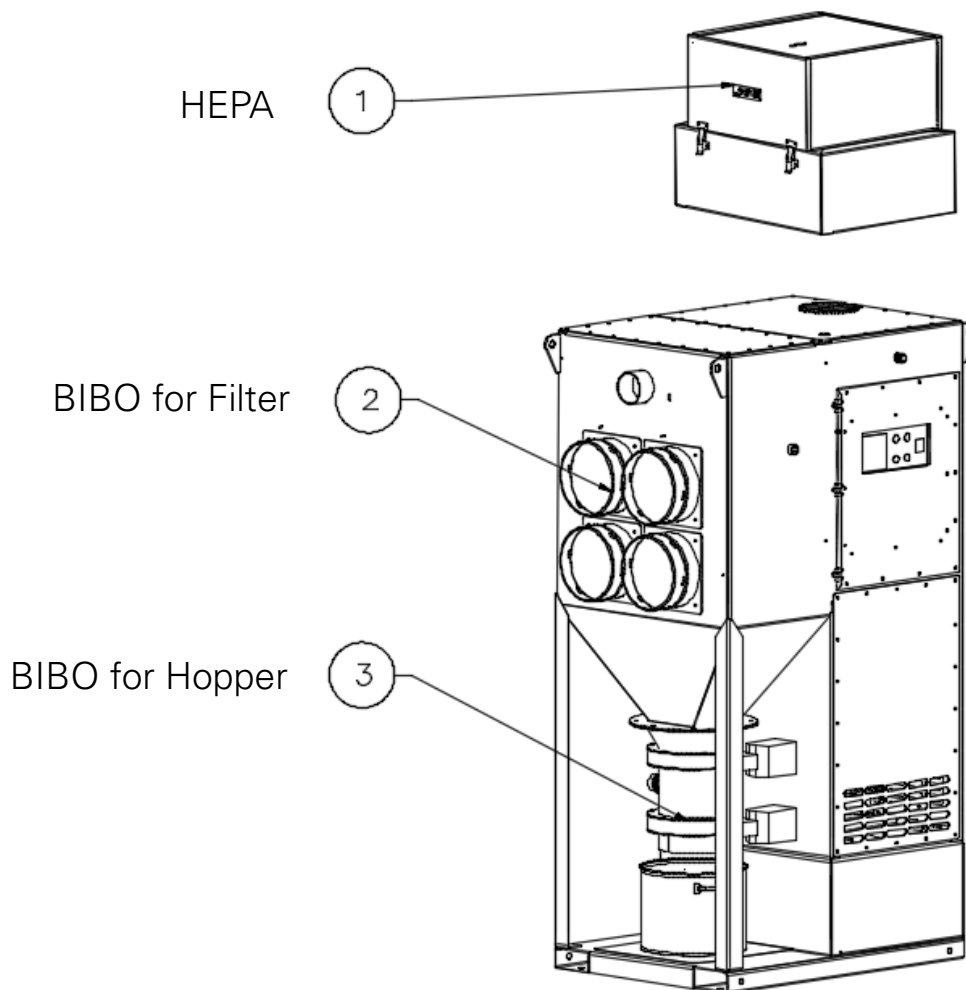

Figure 7
BIBO Module (Option)

6.0 Trouble shooting



WARNING

- Disconnect all power before servicing to prevent injury or extensive damage.
- Direct compressed air supply towards human body or equipment will cause serious injury, shut off and bleed compressed air supply before servicing any compressed air components.
- Automatically cut off of system power indicates abnormal function of electrical components. Requires a qualified electrician according to local codes to check all electrical work.

Problem	Probable Cause	Remedy
Fan does not start	Not wired correctly.	Check and correct internal motor wiring for proper connections for your voltage (see Wiring Diagram)
	Proper wire size not used for motor	Rewire per national and local electric codes for proper wire size.
Fan set starts, but does not keep running	Incorrect overload protection is installed	Check for proper motor overload protection. Reset or replace if needed for proper value.
	Dust collector doors are open or not closed tight	Tighten doors securely.
	Hopper open to atmosphere	Install dust bin under hopper and seal the access door securely.
	Electrical circuit fuses	Check if the supply circuit has sufficient power to run all equipment.
Excessive noise/vibration of the fan	Dust deposit on the blades	Clean the blades.
	Worn blades	The fan wheel has to be replaced.
	Worn bearings	The bearings have to be replaced.
Dust emission	Filter elements installed improperly	Check that gaskets on the filter element(s) are firmly pressed to the tube sheet (the wing nuts of the filter elements should be fully tightened by hand).
	Filter element damage, dents in the end caps, gasket damage or holes in pleated media	Replace the filter elements.
	Doors not airtight	Tighten doors securely and check sealing.



If this happens, it should be rectified at once

Problem	Probable Cause	Remedy
Insufficient airflow	Fan wheel rotating wrong way	Check fan rotation. Refer to 3.0
	Openings not properly sealed	Check doors, that they are closed and tightened securely. Also check hopper area that openings are closed off and that the hopper dust disposal is installed.
	Outlet is restricted	Check outlet for blockage. Remove material or debris that is blocking the outlet.
	Filter elements plugged :	
	a. Lack of compressed air	Check compressed air supply for under 6 bar.
	b. Pulse cleaning not energized	Refer to the trouble shooting guide from the Control manual.
	c. Dust disposal system is too full or plugged	Clean out dust disposal system..
	d. Hopper full of dust or plugged	Clean out the hopper.
e. Filter elements need to be replaced	Replace the filter elements	
Solenoid valves/diaphragm valves are not functioning:	Check for debris, obstruction, and valve wear or diaphragm failure by removing the diaphragm cover on the solenoid valves. Also check for solenoid leakage damage. If diaphragm valves or solenoid valves are damaged replace it or replace damaged part(s).	
a. Solenoid valves/diaphragm valves are leaking compressed air		
b. Pulse control printed circuit board has failed or is out of adjustment	Refer to Operating manual of the Controls.	
Excessive noise of a diaphragm valve	Failure on the diaphragm valve	Check for debris, obstruction, valve wear or failure by removing the diaphragm cover. If the diaphragm valve is damaged, replace it or replace damaged part(s).

7.0 Control Panel

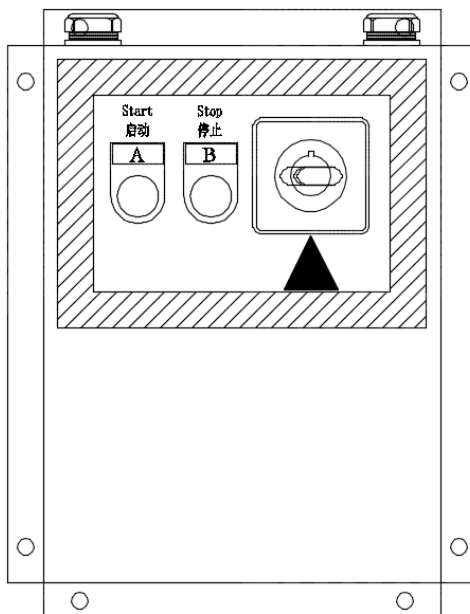

Figure 8
HV150/300 Control Panel (Standard)

7.1 Control panel functions

The "Start/Stop" button is for fan motor on/off. And these 2 buttons also provides lights for indication of fan motor run/stop status.

Fan motor overload protection and overload indication (Alarm).

- When press the "Start" button, the fan motor will be powered up. When the start button is started the "Start" green indication light will light up;
- When press the "Stop". The fan motor will be turn off. When push the "Stop" button, the "Stop" red indication light will light up and the fan motor dis-energized.

7.2 Operation

Ensure that the control panel is correctly installed onto the dust collector before starting up (check main power supply connections, all electrical cable connections, fan starter/fan motor connections, solenoid/diaphragm valve connections, compressed air tubing connections, etc.) For safety of personnel and equipment, ensure that the control panel is properly grounded.

- Turn the main power supply switch to "ON" position.
- There is overload protection for the fan motor, the setting of AMPs according to the nameplate of the fan motor. When the "Stop" indication light lights up it signifies that the fan motor is overloaded and has stopped.
- To terminate electrical power supply to the pulsing control, please ensure that the fan motor is shut down before turning the main power supply switch to the "OFF" position.

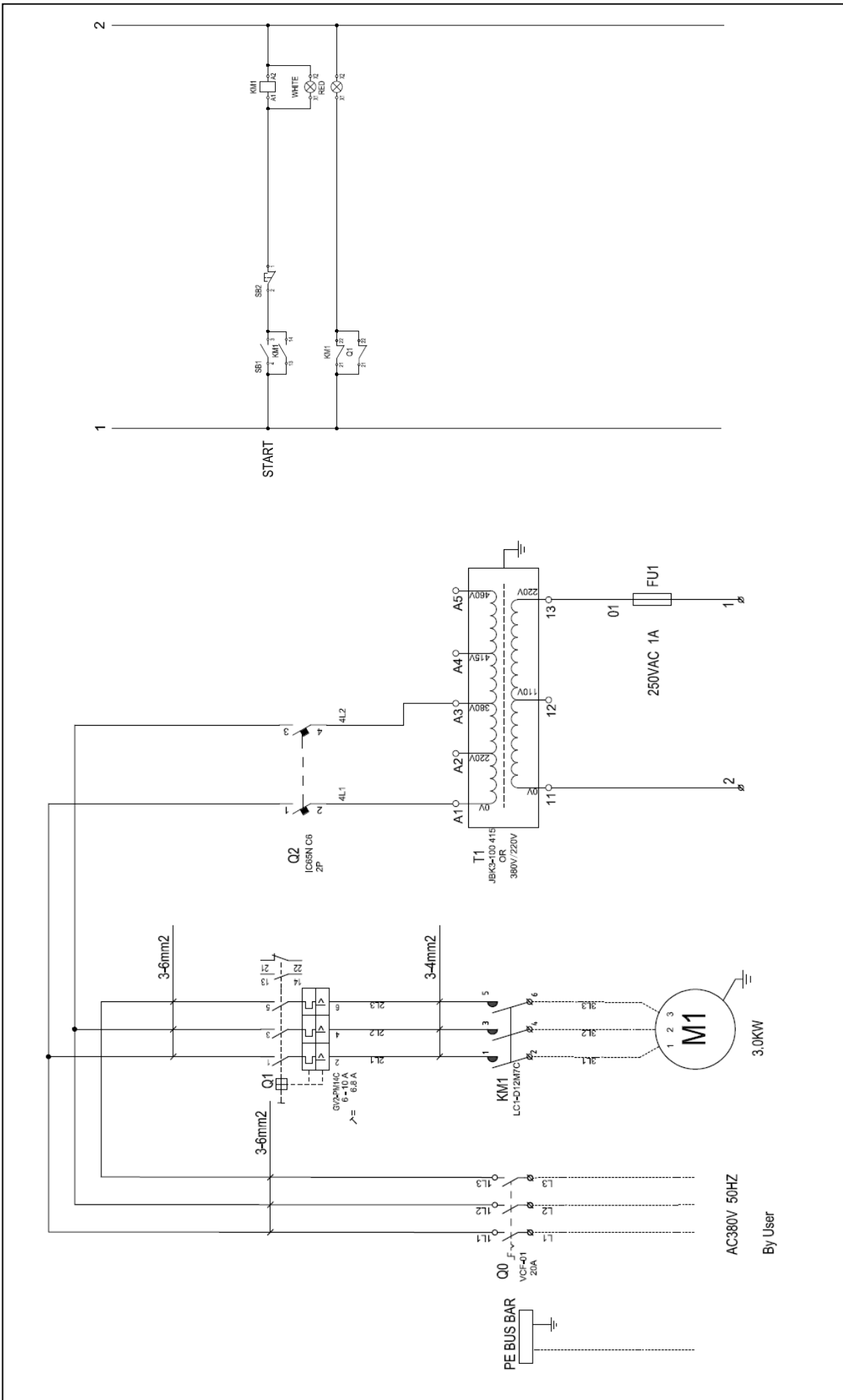

Figure 9
HV150/300 Wiring Diagram

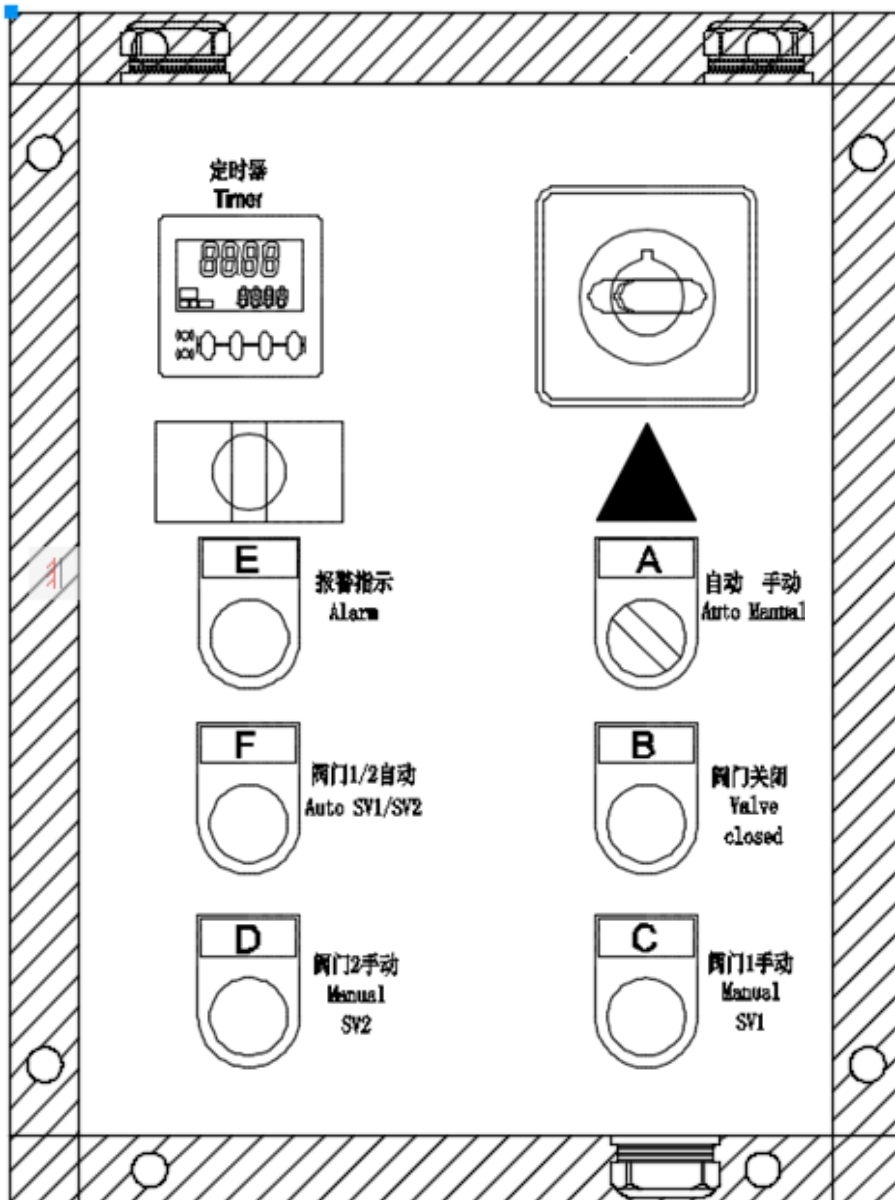

Figure 10

HV150/300 BIBO Control Panel (Option)

7.3 HV150/300 BI/BO Control panel functions (Option)

The "Auto/Manual" selection switch for AUTO or MANUAL cleaning control model selecting. When the selection switch is at the "Manual" position, the valve 1 and 2 can be open manually. When the selection switch is at the "Auto" position, the valve 1 and 2 will be controlled by the timer.

Fan motor overload protection and overload indication (Alarm).

- When press the "Valve closed" button the valves will be closed and the red indication light will light up;
- When press the "Manual SV1/SV2" and the mode selection switch is set at "Manual" position, the valve 1 and valve 2 can be open buttons respectively. When push the "Manual SV1/SV2" button, the green indication light will light up
- When press the "Auto SV1/SV2" button and the "Auto/Manual" selection switch is set at "Auto" position, the valve 1 and 2 will be controlled by the timer, And the valve 1 and valve 2 will be opened by turns.
- We use the OMRON H5CZ-L8 Bidirectional timer to control the valve 1 and valve 2 alternately, and we can set the alternating time from 9.999s to 9999h freely.

7.4 HV150/300 BI/BO Operation (Option)

Ensure that the control panel is correctly installed onto the dust collector before starting up (check main power supply connections, all electrical cable connections, fan starter/fan motor connections, solenoid/diaphragm valve connections, compressed air tubing connections, etc.) For safety of personnel and equipment, ensure that the control panel is properly grounded.

- Turn the main power supply switch to "ON" position.
- There is overload protection for the fan motor, the setting of AMPs according to the nameplate of the fan motor. When the "Alarm" indication light lights up it signifies that the fan motor is overloaded and has stopped.
- To terminate electrical power supply to the pulsing control, please ensure that the fan motor is shut down before turning the main power supply switch to the "OFF" position.

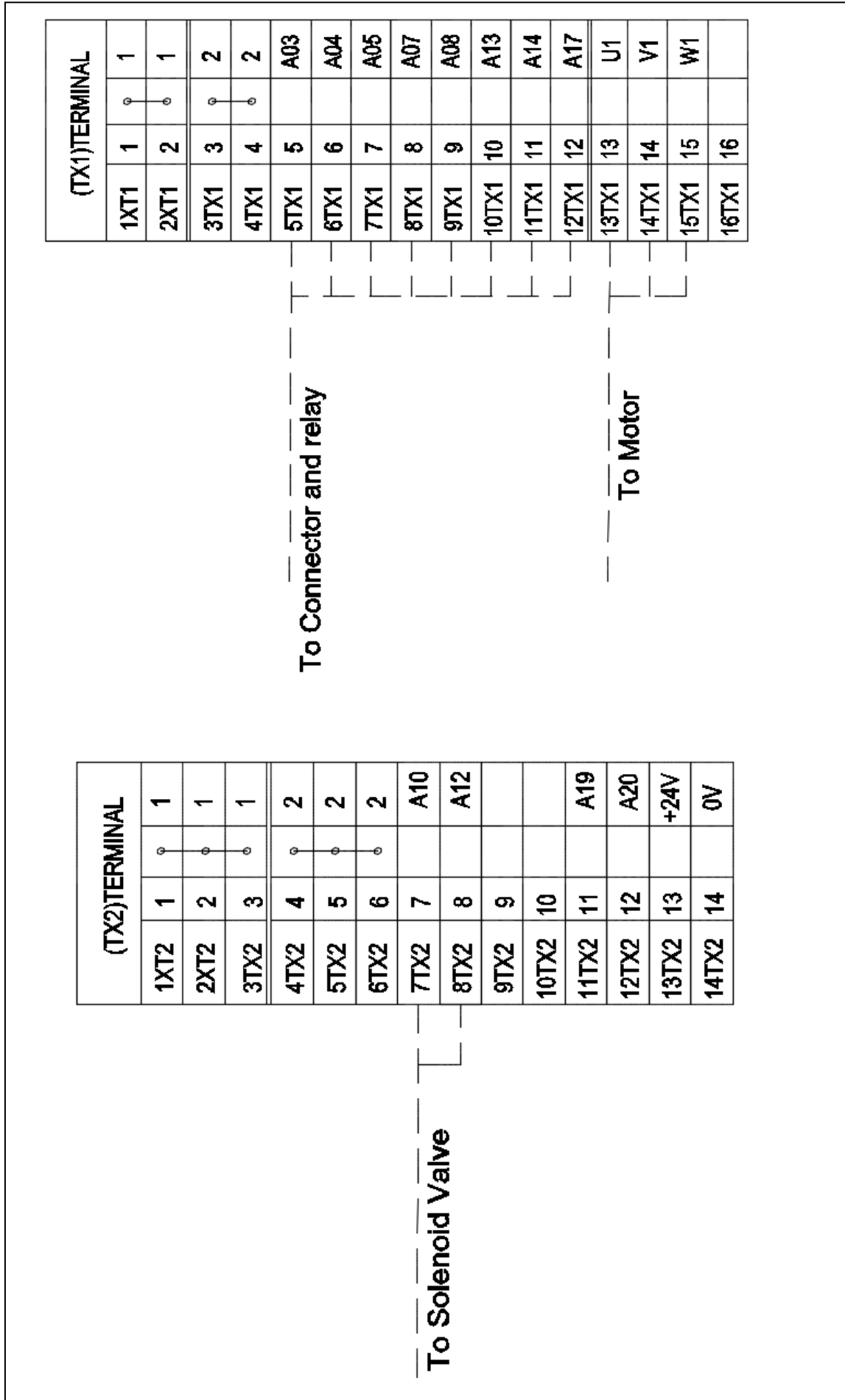

Figure 11
HV150/300 BIBO Electrical Terminal Block (Option)

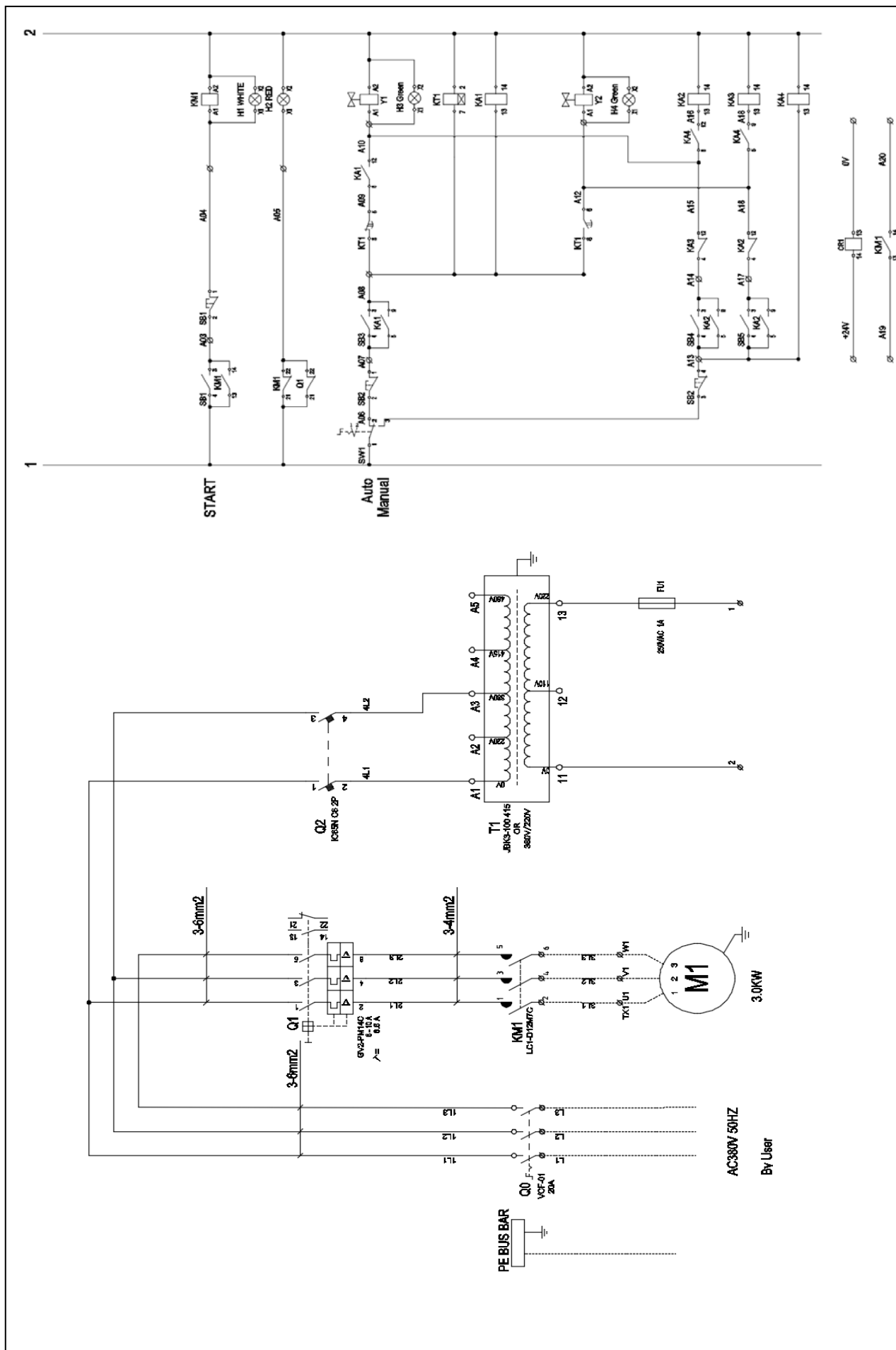

Figure 12 HV150/300 BIBO Wiring Diagram (Option)

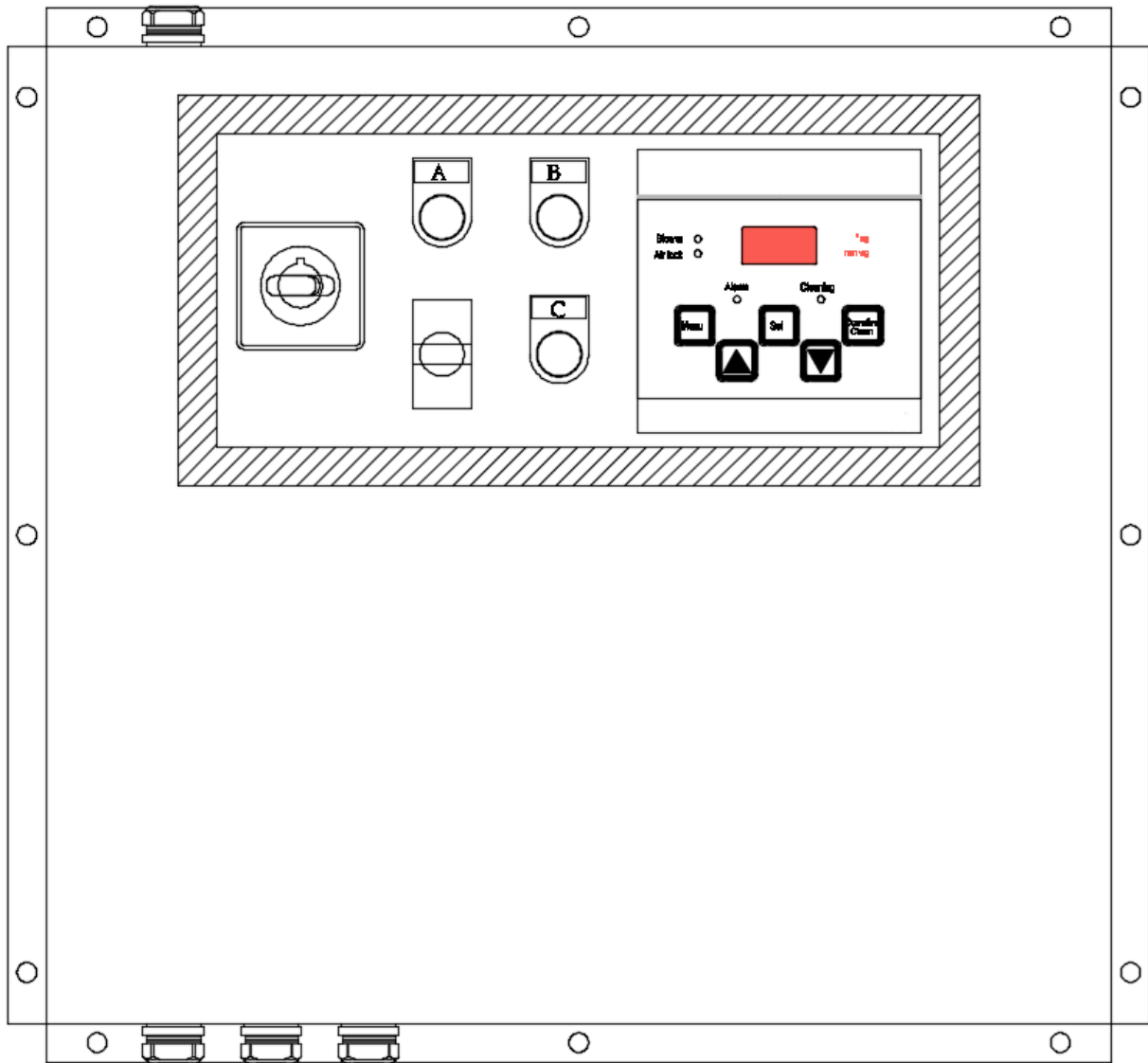

Figure 13

HV600/1000 (BIBO) Control panel

7.5 HV600/1000 (BIBO for option)

Control panel functions

The "Local/Remote" selection switch is for LOCAL or REMOTE fan motor on/off control selecting. And the control panel also provides one voltage free contact output for indication of fan motor run/stop status.

The "Auto/Manual" selection switch for AUTO or MANUAL cleaning control model selecting. When the selection switch is at the "Manual" position, the collector will clean continually. When the selection switch is at the "Auto" position, the collector cleaning will be controlled by the Torit Delta P-C01 controller on the panel, and the control panel can also provide down-time cleaning.

Fan motor overload protection and overload

- When the "Local/Remote" selection switch is set at "Remote" position, the start/stop of the fan motor can be controlled remotely. When the remote control switch is closed the "Running" green indication light will light up and the fan motor will be powered up; when the remote control switch is opened the "Running" green indication light will go off, and the fan motor dis-energized.
- When the "Local/Remote" selection switch is set at "Local" position all control operations need to be carried out locally at the control panel. The fan motor can be turn on and off by pushing the "Fan Start" and "Fan Stop" buttons respectively. When push the "Fan Start" button, the "Running" green indication light will light up and the fan motor will be powered up; when push the "Fan Stop" button the "Running" green indication light will go off and the fan motor dis-energized.
- When the "Auto/Manual" selection switch is set at "Manual" position, the cleaning will process continually. When the "Auto/Manual" selection switch is set at "Auto" position the cleaning will be controlled by the Torit Delta P-C01 controller on the panel. At any time the cleaning pulse is activated, the "Cleaning" indication light on the Delta P-C01 controller will light up.

7.6 HV600/1000 (BIBO for option)

Operation

Ensure that the control panel is correctly installed onto the dust collector before starting up (check main power supply connections, all electrical cable connections, fan starter/fan motor connections, solenoid/diaphragm valve connections, compressed air tubing connections, etc.) For safety of personnel and equipment, ensure that the control panel is properly grounded.

- Turn the main power supply switch to "ON" position. The Torit Delta P-C01 controller will power up. All operating instructions for the Torit Delta P-C01 controller are mentioned in a separate manual of Delta P-C01.
- There is overload protection for the fan motor, the setting of AMPs according to the nameplate of the fan motor. When the "Error" indication light lights up it signifies that the fan motor is overloaded and has stopped.
- To terminate electrical power supply to the pulsing control, please ensure that the fan motor is shut down before turning the main power supply switch to the "OFF" position.
- For HV 600/1000 BIBO model will add 2 valves to discharge the dust and particles, and these 2 valves will working alternately and the alternating time can be setting in the Logo controller.

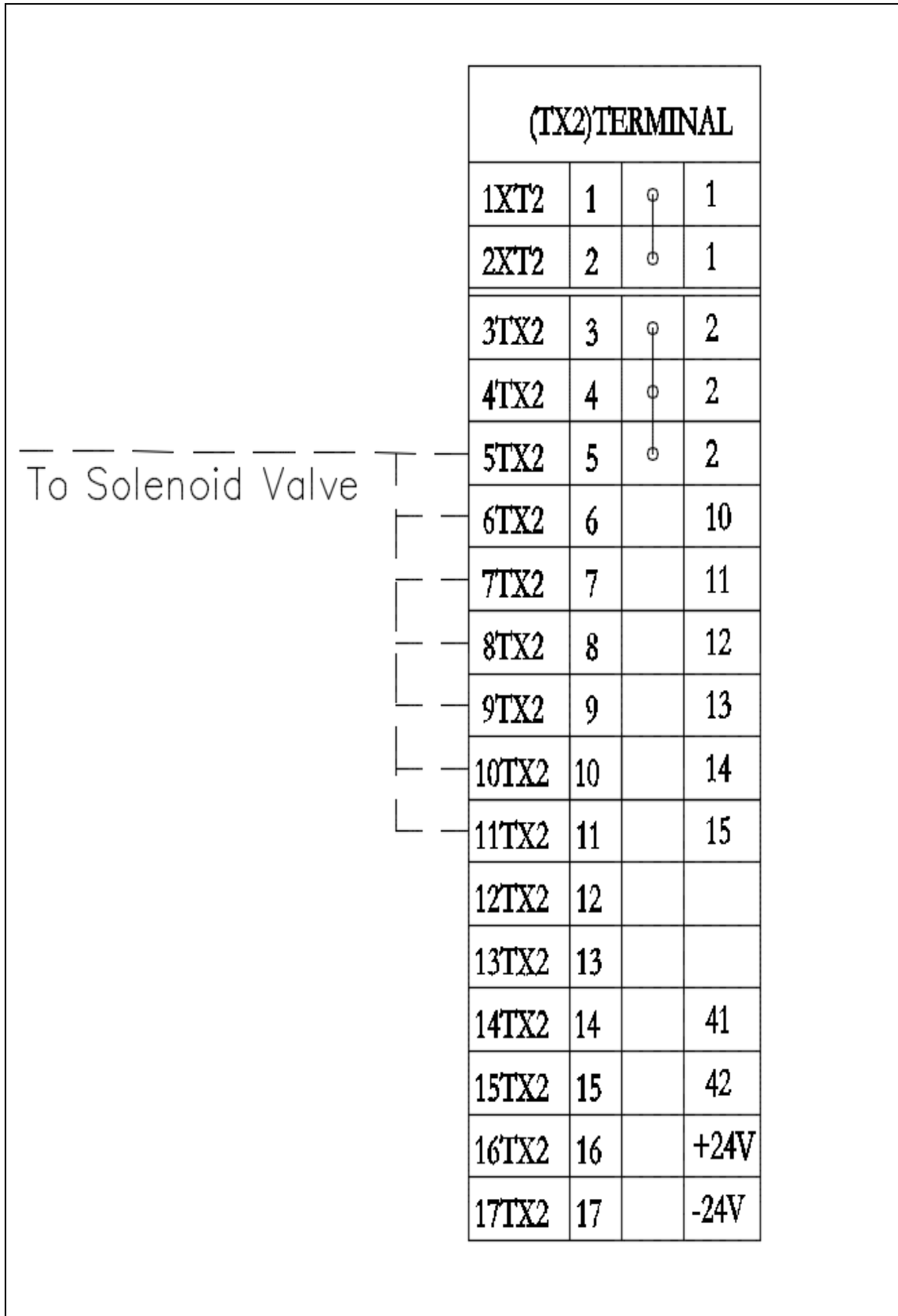

Figure 14
HV1000 BIBO Electrical Terminal Block

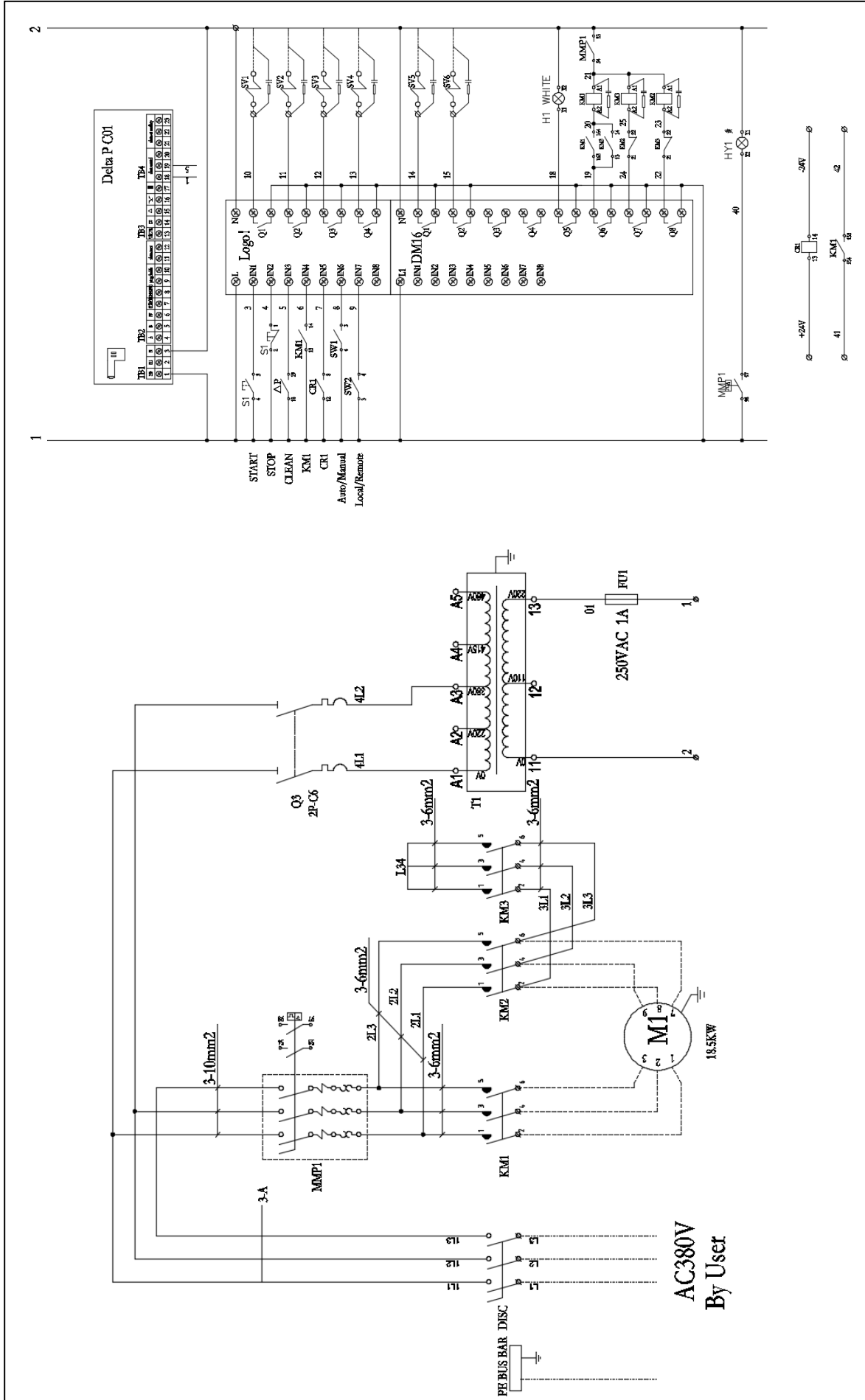

Figure 15
HV1000 BIBO Wiring Diagram shown (option)

8.0 Spare Parts

Item	Description	Part number
1	Filter Assembly-Ultra Web FR	P191115
2	Filter Assembly-Ultra Web SB	P031851
3	Filter Assembly-Ultra Web AS	P034080
4	Diaphragm valve	8PP-19307-00
5	Solenoid Valve(HV600)	8PP-48948-10
6	Solenoid Valve(HV1000)	8PP-48948-09
7	Relief valve	8PP-AK00099-50
8	Delta P-C01 115V/230V	8PP-AK01004-00
9	High temperature HEPA	P280617

Note: When ordering parts, give model number and serial number of dust collector, description and quantity of parts desired.

The Donaldson Torit Warranty

Donaldson does not warrant against damages due to corrosion, abrasion, normal wear and tear, product modification, or product misapplication. Donaldson also makes no warranty whatsoever as to any goods manufactured or supplied by others including electric motors, fans and control components. After Donaldson has been given adequate opportunity to remedy any defects in material or workmanship, Donaldson retains the sole option to accept return of the goods, with freight paid by the purchaser, and to refund the purchase price for the goods after confirming the goods are returned undamaged and in usable condition. Such a refund will be in the full extent of Donaldson's liability. Donaldson shall not be liable for any other costs, expenses or damages whether direct, indirect, special, incidental, consequential or otherwise. The terms of this warranty may be modified only by a special warranty document signed by a Director, General Manager or Vice President of Donaldson. Failure to use genuine Donaldson replacement parts may void this warranty. THERE EXIST NO OTHER REPRESENTATIONS, WARRANTIES OR GUARANTEES EXCEPT AS STATED IN THIS PARAGRAPH AND ALL OTHER WARRANTIES INCLUDING MERCHANTABILITY AND FITNESS FOR A PARTICULAR PURPOSE, WHETHER EXPRESS OR IMPLIED ARE HEREBY EXPRESSLY EXCLUDED AND DISCLAIMED.



Donaldson.
FILTRATION SOLUTIONS

Parts and Service

For genuine Donaldson replacement filters and parts, call the Parts Express Line. For faster service, have unit's model and serial number, quantity, part number, and description available.

Donaldson Australasia
Tel: 1800 503 878 (AU)
Tel: 0800 743 387 (NZ)
Website: www.donaldsonfilters.com.au

Donaldson China
Tel: 400 820 1038
Website: www.donaldson.cn

Donaldson South Asia
Tel: +91 124 480 7536
Website: www.india.donaldson.com

Donaldson Japan
Tel: +81 42 540 4114
Website: www.donaldson.co.jp

Donaldson Korea
Tel: +82 251 733 33
Website: www.donaldson.co.kr

Donaldson Europe
Tel: +32 16 383 811
Website: www.donaldson.com

Donaldson Southeast Asia
Tel: +65 6349 8168
Website: www.asia.donaldson.com

Donaldson USA
Tel: +1 800 365 1331
Website: www.donaldson.com

Donaldson Company, Inc. is the leading designer and manufacturer of dust, mist, and fume collection equipment used to control industrial-air pollutants. Our equipment is designed to help reduce occupational hazards, lengthen machine life, reduce in-plant maintenance requirements, and improve product quality.

© 2017 Donaldson Company,
Inc. Printed in APAC

IOM AK0303201, Revision 0
April 2017