

Unimaster Dust Collectors

Series UMA 70-250

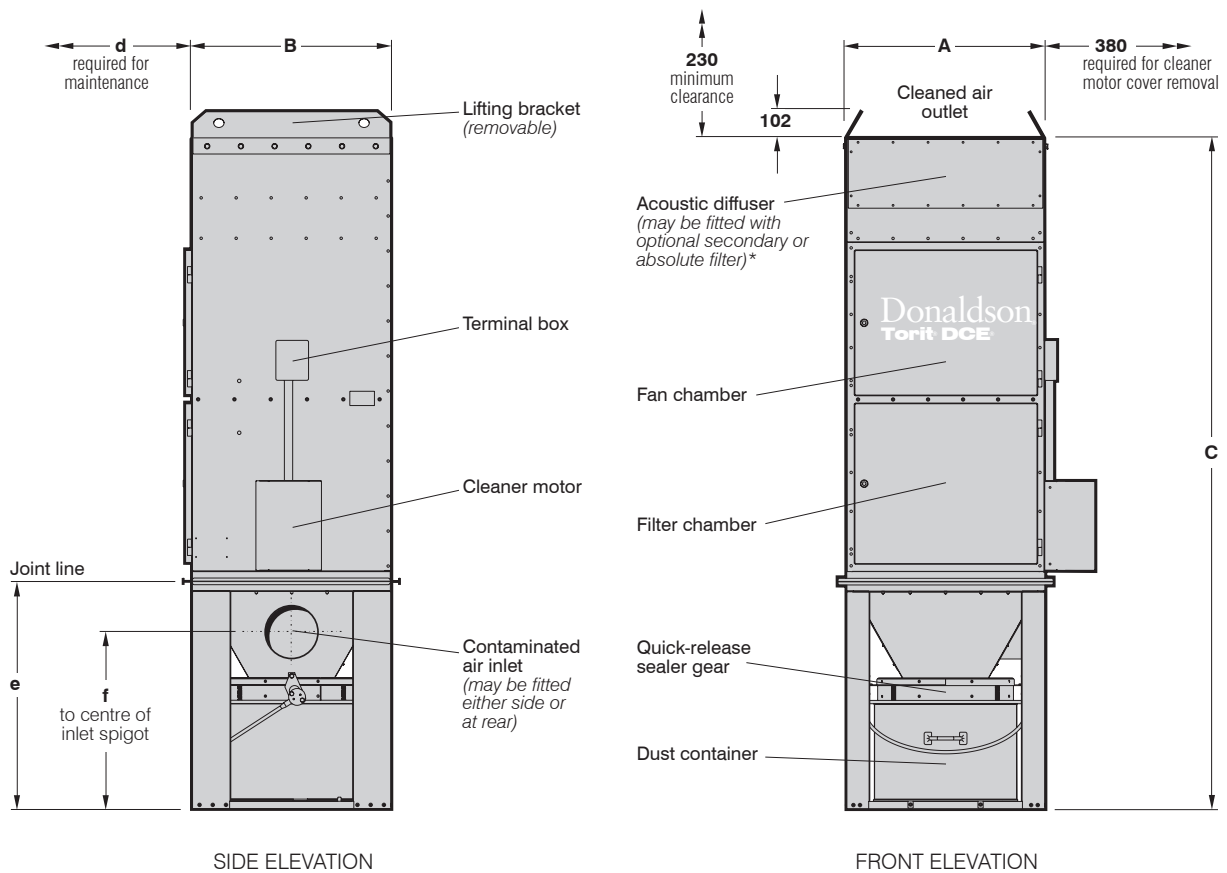

UNIMASTER DUST COLLECTOR WITH DUST CONTAINER

UMA 153 illustrated. Suitable for inside locations. *Secondary filter and absolute filter not available for UMA 72 dust collector.

Type	Filtration area	DIMENSIONS in mm							Inlet spigot (inside dia.) mm	Fan	Motor rating	Dust container	Net weight (approx.)
		A	B	C	d	e	f						
UMA 72	6.23 m ²	575	575	2029	600	729	648	∅ 101	G1	0.75 kW	55 litre	203 kg	
UMA 103	9.29 m ²	765	575	2535	800	883	685	∅ 203	G1	0.75 kW	80 litre	295 kg	
									K3	1.50 kW		300 kg	
UMA 153	13.94 m ²	765	765	2591	800	883	685	∅ 203	G1	0.75 kW	80 litre	333 kg	
									K3	1.50 kW		338 kg	
									K5	2.20 kW		353 kg	
									K7	3.00 kW		378 kg	
									G8	5.50 kW		393 kg	
UMA 253	22.67 m ²	1146	765	2942	1150	1099	883	∅ 254	G1	0.75 kW	80 litre	445 kg	
									K3	1.50 kW		450 kg	
									K5	2.20 kW		465 kg	
									K7	3.00 kW		490 kg	
									G8	5.50 kW		505 kg	

Unimaster Dust Collectors – Series UMA 70-250

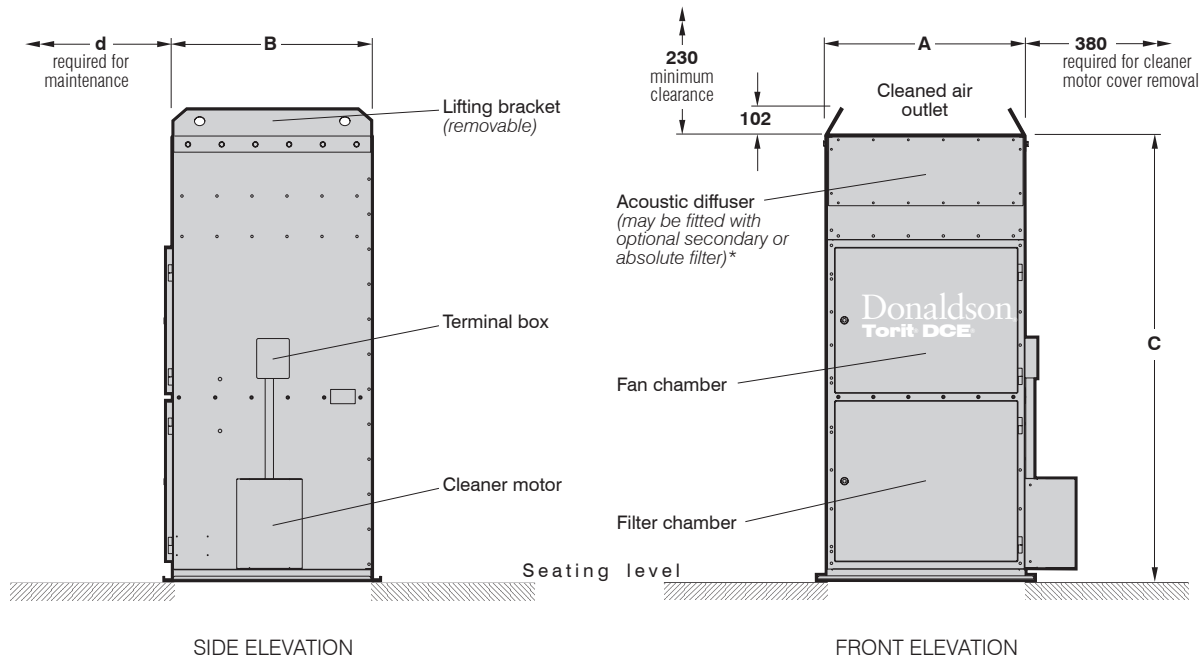

UNIMASTER HOPPER TYPE DUST COLLECTOR

UMA 150H illustrated. Suitable for inside locations. *Secondary filter and absolute filter not available for UMA 70H dust collector.

SPECIFICATION								
Type	Filtration area	DIMENSIONS in mm				Fan	Motor rating	Net weight (approx.)
		A	B	C	d			
UMA 70H	6.23 m ²	575	575	1338	600	G1	0.75 kW	170 kg
						K3	1.50 kW	240 kg
UMA 100H	9.29 m ²	765	575	1652	800	G1	0.75 kW	270 kg
						K3	1.50 kW	275 kg
						K5	2.20 kW	290 kg
						K7	3.00 kW	315 kg
						G8	5.50 kW	330 kg
UMA 150H	13.94 m ²	765	765	1708	800	G1	0.75 kW	355 kg
						K3	1.50 kW	360 kg
						K5	2.20 kW	375 kg
						K7	3.00 kW	400 kg
						G8	5.50 kW	415 kg
UMA 250H	22.67 m ²	1146	765	1843	1150	G1	0.75 kW	355 kg
						K3	1.50 kW	360 kg
						K5	2.20 kW	375 kg
						K7	3.00 kW	400 kg
						G8	5.50 kW	415 kg

DUST CONTAINER				Typical dust densities	
Size	Approx net weight	Dust	Density with 50% voidage		
55 litre (2 cu.ft.)	5 kg	Sander	0.13 kg/litre		
80 litre (3 cu.ft.)	6 kg	Graphite	0.80 kg/litre		
A reasonable total load for removal by hand would be 25 kg			Sand	1.33 kg/litre	
			Iron	3.58 kg/litre	
			Steel	3.72 kg/litre	

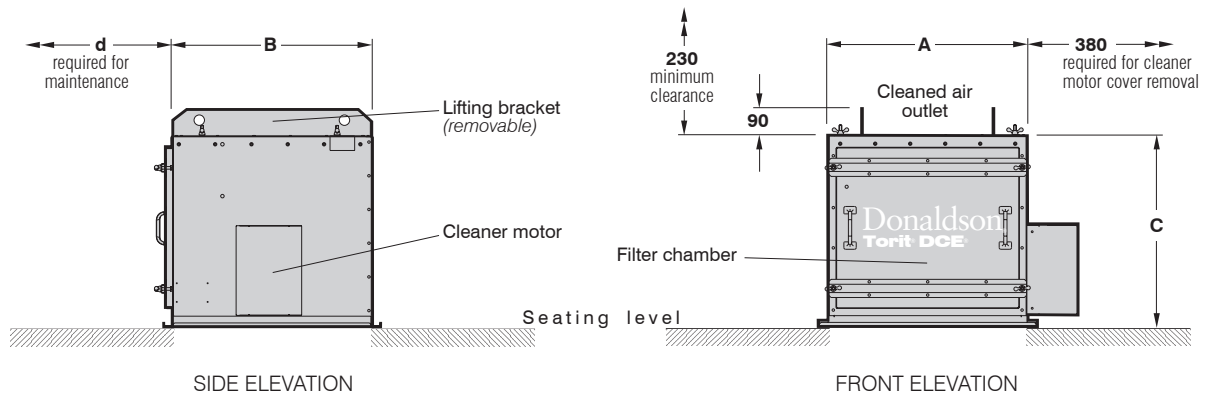

UNIMASTER VENTING TYPE DUST COLLECTOR

UMA 150V illustrated. Suitable for inside locations and outside when fitted with optional weather cowl.

SPECIFICATION						
Type	Filtration area	A	B	C	d	Net weight (approx.)
UMA 70V	6.23 m ²	575	575	678	560	93 kg
UMA 100V	9.29 m ²	765	575	678	560	114 kg
UMA 150V	13.94 m ²	765	765	735	760	135 kg
UMA 250V	22.67 m ²	1146	765	735	760	175 kg

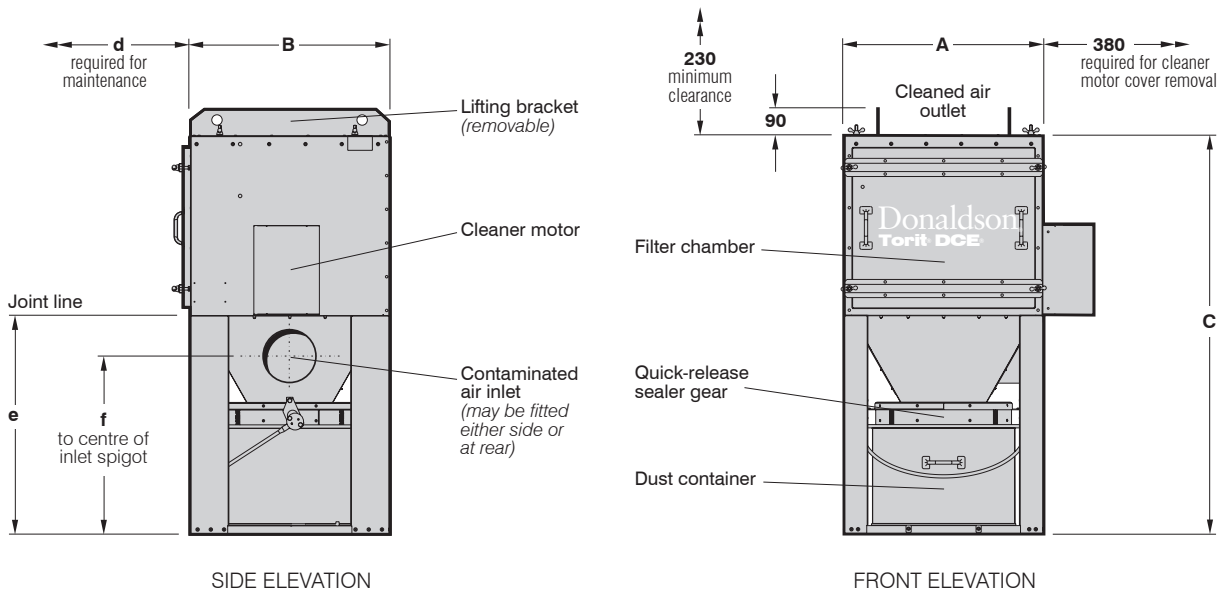

UNIMASTER VENTING TYPE DUST COLLECTOR WITH DUST CONTAINER

UMA 153V illustrated. Suitable for inside locations and outside when fitted with optional weather cowl.

SPECIFICATION										
Type	Filtration area	A	B	C	d	e	f	Inlet spigot (inside dia.) mm	Dust container	Net weight (approx.)
UMA 72V	6.23 m ²	575	575	1369	560	729	648	∅ 101	55 litre	126 kg
UMA 103V	9.29 m ²	765	575	1485	560	845	685	∅ 203	80 litre	174 kg
UMA 153V	13.94 m ²	765	765	1542	760	845	685	∅ 203	80 litre	199 kg
UMA 253V	22.67 m ²	1146	765	1758	760	1061	883	∅ 254	80 litre	265 kg

Type	DIMENSIONS in mm		
	A	B	c
UMA 70	225	225	116
UMA 100	295	250	116
UMA 150	320	320	116
UMA 250	340	340	403

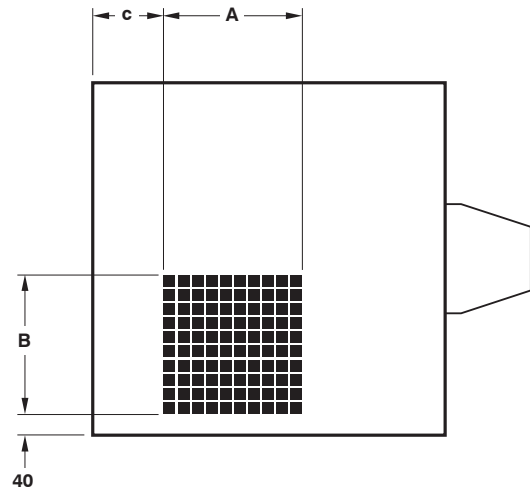

CLEANED AIR OUTLET DETAILS

UMA 150 illustrated

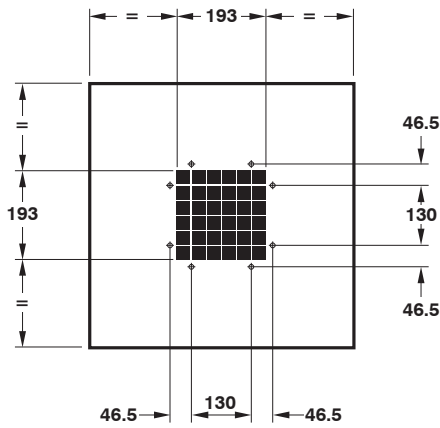

UMA 70V

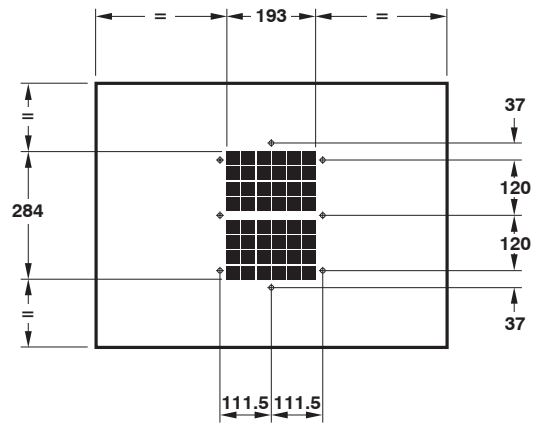

UMA 100V and 150V

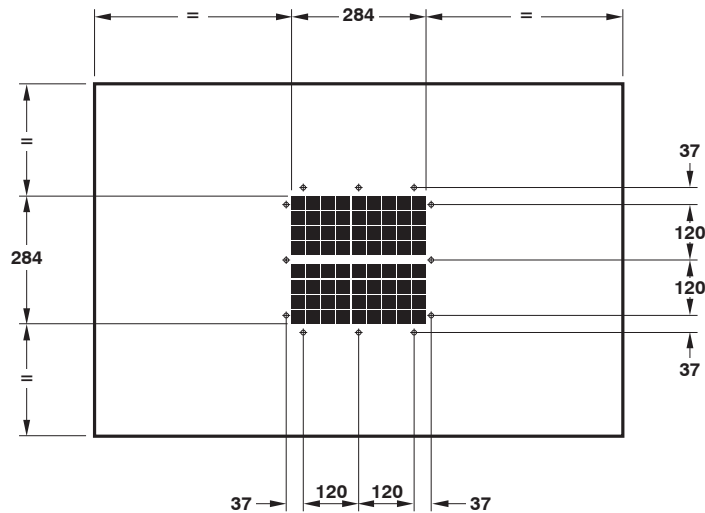

UMA 250V

CLEANED AIR OUTLET DETAILS FOR VENTING TYPE COLLECTORS

All holes $\varnothing 4$ mm

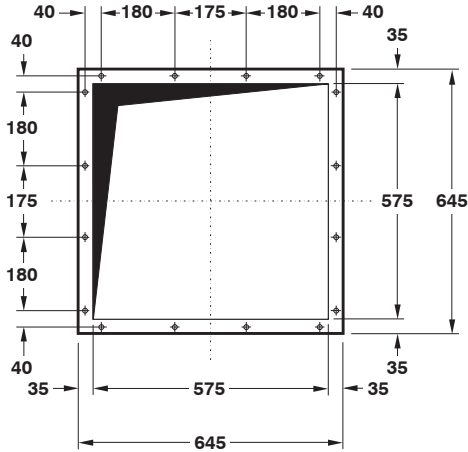

UMA 70H and 70V

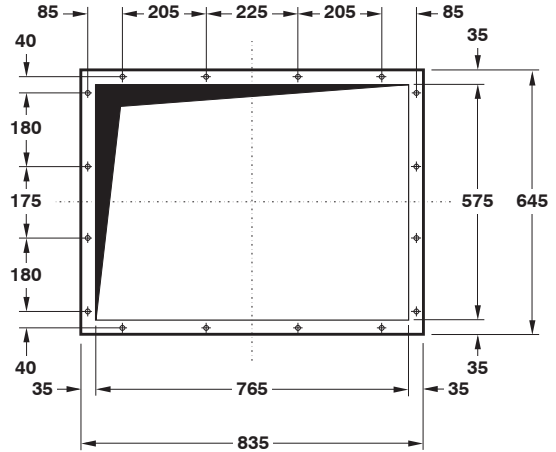

UMA 100H and 100V

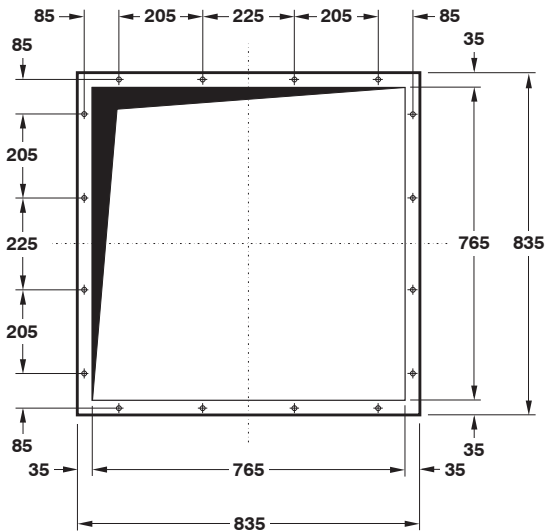

UMA 150H and 150V

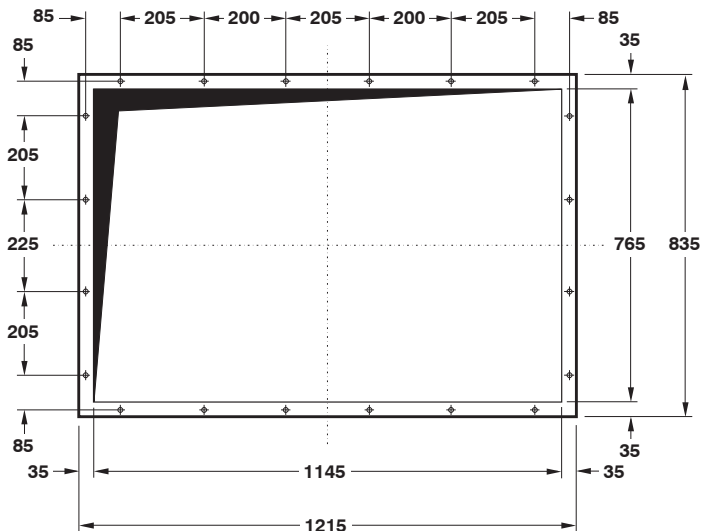

UMA 250H and 250V

APERTURE AND MOUNTING FLANGE DETAILS FOR HOPPER AND VENTING TYPE COLLECTORS

All holes $\varnothing 12$ mm for M10 bolts

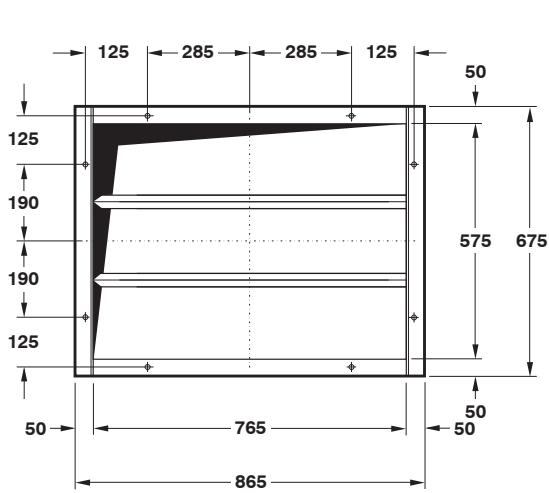

UMA 100STU

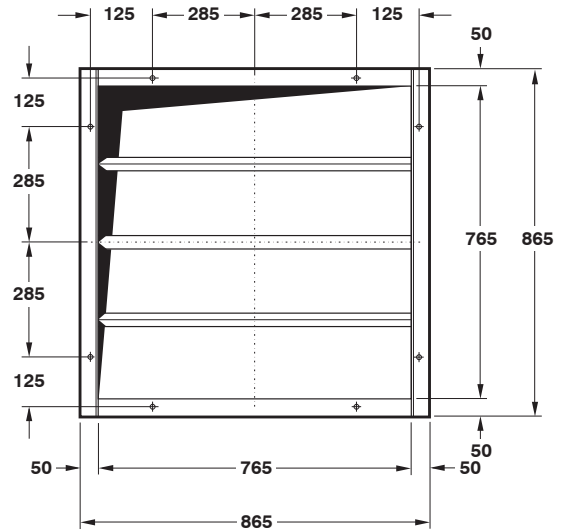

UMA 150STU

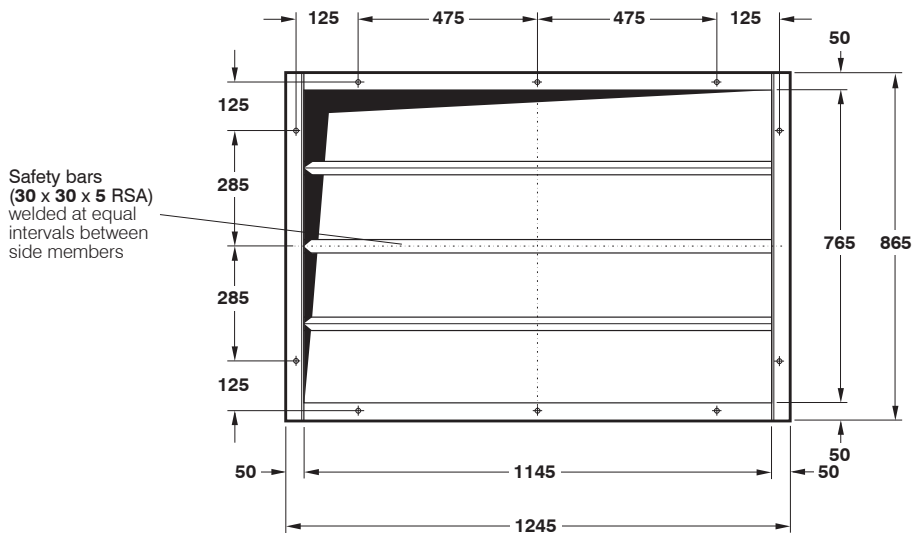

UMA 250STU

APERTURE AND MOUNTING FLANGE DETAILS FOR SACK TIPPING UNITS

All holes $\varnothing 12$ mm for M10 bolts

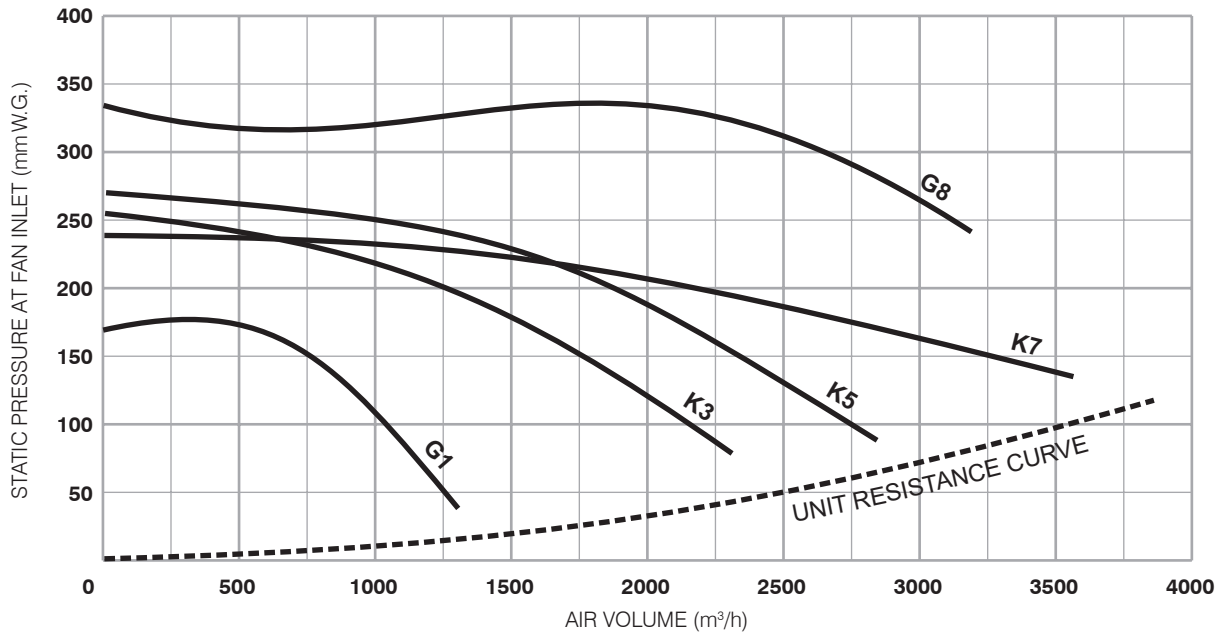

UNIT PERFORMANCE CURVES

FAN SELECTION

These curves indicate static pressure available at fan inlet for a given volume when fitted inside a Unimaster dust collector.

To select the most suitable fan for a given application:

- 1 Determine the air volume, in m³/h, needed to entrain the dust.
- 2 Read off the unit resistance, in mm W.G., at air volume required.
- 3 Assess pressure drop over filter bags prior to cleaning, usually 50 to 100 mm W.G.
- 4 Estimate pressure drop through connected system – i.e. between point of entrainment and collector inlet.
- 5 The sum of **2**, **3** and **4** = W.G. required.
- 6 Consult graph for fan performances available.

Sack Tipping Units have K3 (1.5 kW) fans with modified outlet to ensure adequate face velocities at the tipping hatch under normal operating conditions. Typically, the exhaust rate for the UMA 250STU is 1275 m³/h (750 cfm).

ELECTRICAL REQUIREMENTS

UCS Controller

Voltage input: 220-240V, Single Phase, 50Hz (for collectors with G1 or K3 fans only)
 218-242V / 380-420V, Three Phase, 50Hz
 250-277V / 440-480V, Three Phase, 60Hz
 or to suit local voltage

Unimaster Dust Collectors – Series UMA 70-250

NOISE LEVELS

Machinery noise levels are an important consideration in the design and selection of new equipment. Several EC Directives and National Laws/Regulations adopting these directives make reference to airborne noise emissions. Actions that employers are required to comply with if employees are subjected to a daily personal noise exposure level of 80 dB(A) or more are also specified.

All Unimaster dust collectors, when fitted with an acoustic diffuser, secondary filter or absolute filter, operating an 8 hour shift, are below this action limit.

WEIGHTED SOUND PRESSURE LEVELS

All readings were taken in normal industrial areas, i.e. semi-reverberant surroundings, with local equipment silent. Measurements were taken at maximum air flow conditions at 1.0 metre radius from the equipment housing and 1.6 metres above base level, using a precision sound level meter and octave filter.

	G1	K3	K5	K7	G8
With acoustic diffuser	65 dB(A)	67 dB(A)	69 dB(A)	69 dB(A) [†]	72 dB(A)
With secondary filter	—*	67 dB(A)	69 dB(A)	69 dB(A)	72 dB(A)
With absolute filter	—*	67 dB(A)	69 dB(A)	69 dB(A)	72 dB(A)

Noise levels of installed equipment may vary due to site conditions.
 *Secondary and absolute filter not supplied with G1 fan. [†]Measured data.

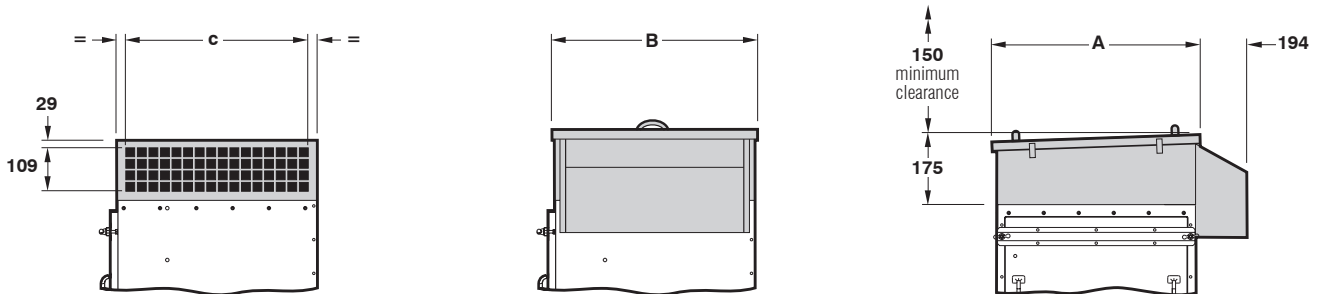

SIDE ELEVATION
 (Detail of cleaned air outlet with weather cowl and lid removed)

SIDE ELEVATION

FRONT ELEVATION

OPTIONAL WEATHER COWL
 UMA 150V illustrated

SPECIFICATION

Type	DIMENSIONS in mm			Net weight (approx.)
	A	B	c	
UMA 70V	585	584	473	12 kg
UMA 100V	775	584	473	12 kg
UMA 150V	775	774	697	19 kg
UMA 250V	1156	774	697	19 kg

Unimaster Dust Collectors – Series UMA 70-250

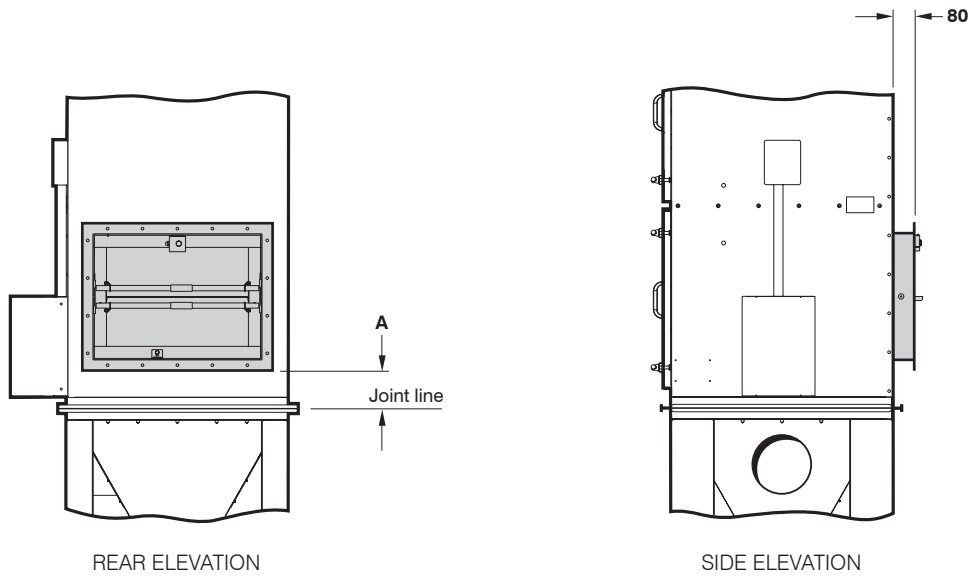

POSITION OF OPTIONAL EXPLOSION RELIEF FLANGE

UMA 153 illustrated

UMA type:	72	103	153	253	70H	100H	150H	250H	70V	100V	150V	250V	72V	103V	153V	253V
Dimension A in mm:	76	114	171	105	114	114	171	105	114	114	171	105	76	76	133	67

If a vent duct is not connected to the explosion relief flange, then a minimum clearance of 500 mm should be made to the rear of the collector to ensure efficient operation of the explosion venting process. Consideration should be given to the local surrounding area in regards to the pressure and flame effects.

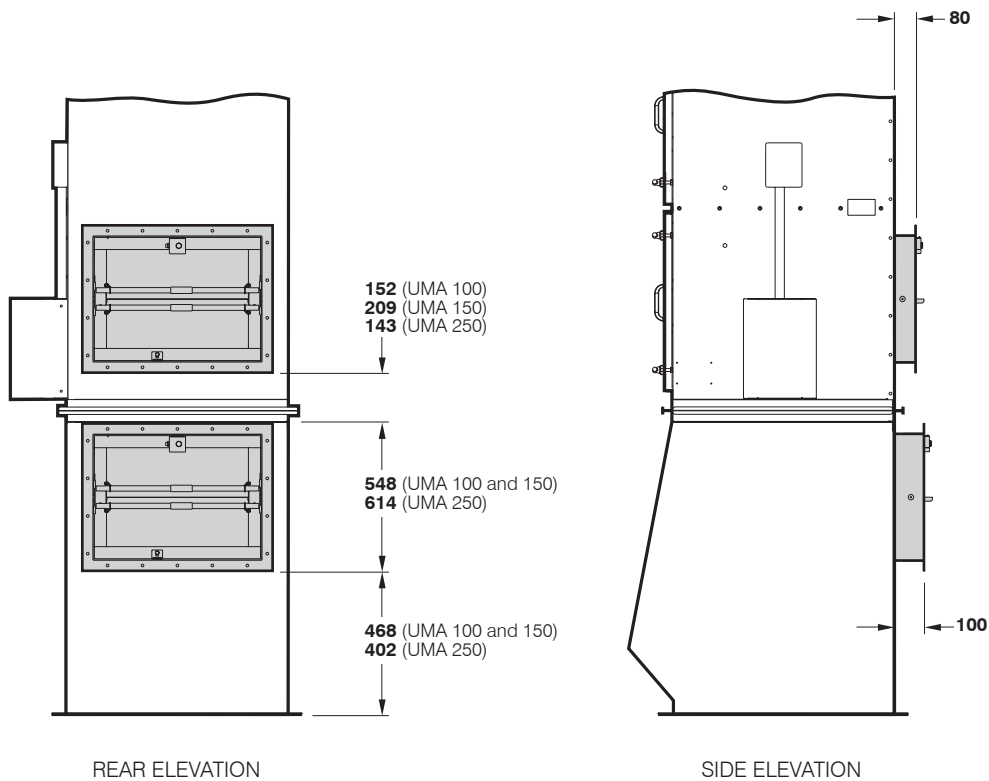

POSITION OF OPTIONAL EXPLOSION RELIEF FLANGES FOR SACK TIPPING UNITS

UMA 150STU illustrated

If vent ducts are not connected to the explosion relief flanges, then a minimum clearance of 500 mm should be made to the rear of the collector to ensure efficient operation of the explosion venting process. Consideration should be given to the local surrounding area in regards to the pressure and flame effects.

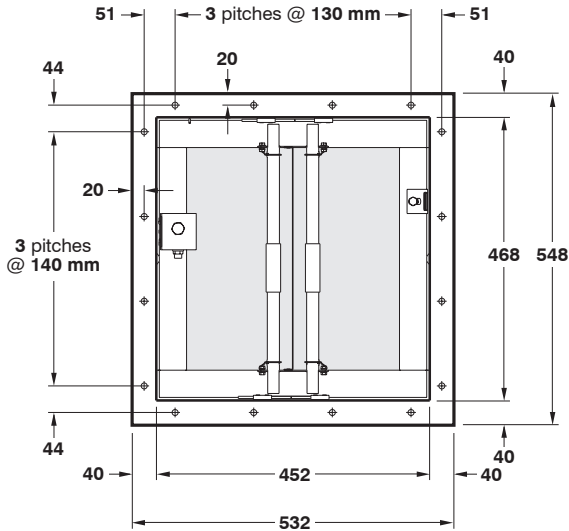

UMA 70

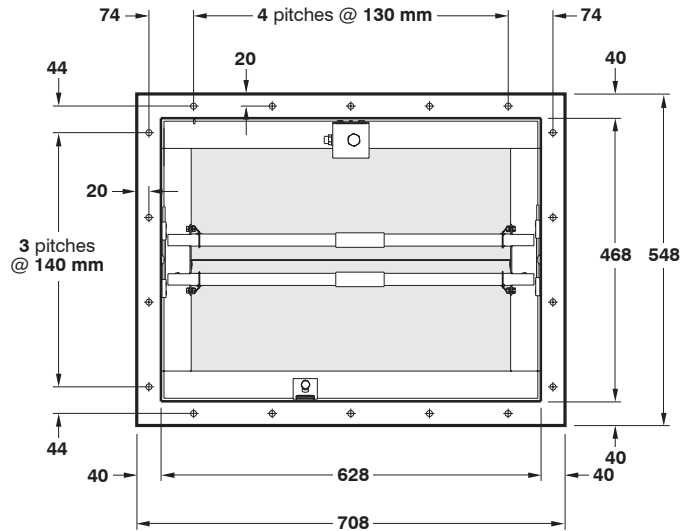

UMA 100 and 150

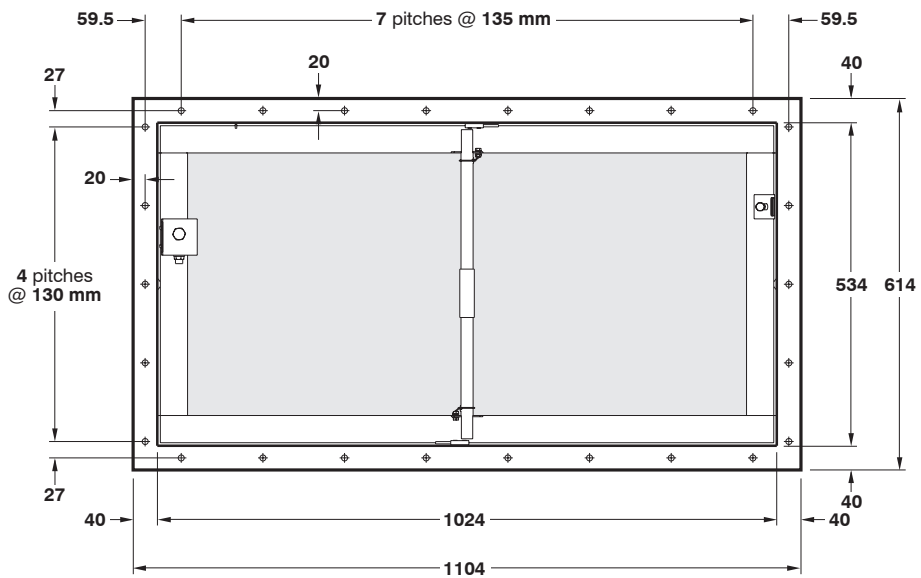

UMA 250

OPTIONAL EXPLOSION RELIEF FLANGE MOUNTING DETAILS

All vertical holes drilled $\varnothing 10$ mm for M8 bolts. All horizontal holes threaded to accept M8 bolts.



Unimaster Dust Collectors – Series UMA 70-250



www.donaldson.com

Humberstone Lane
Thurmaston
Leicester LE4 8HP
England

Tel +44 (0)116 269 6161
Fax +44 (0)116 269 3028

Email: IAF-uk@donaldson.com

Research Park Building No. 1303
Interleuvenlaan 1
B-3001 Leuven (Heverlee)
Belgium

Tel +32 (0)16 383 970
Fax +32 (0)16 383 938

Email: IAF-europe@donaldson.com