

Ambient Collection System

AT-3000

Installation and Operation Manual

Installation, Operation, and Service Information

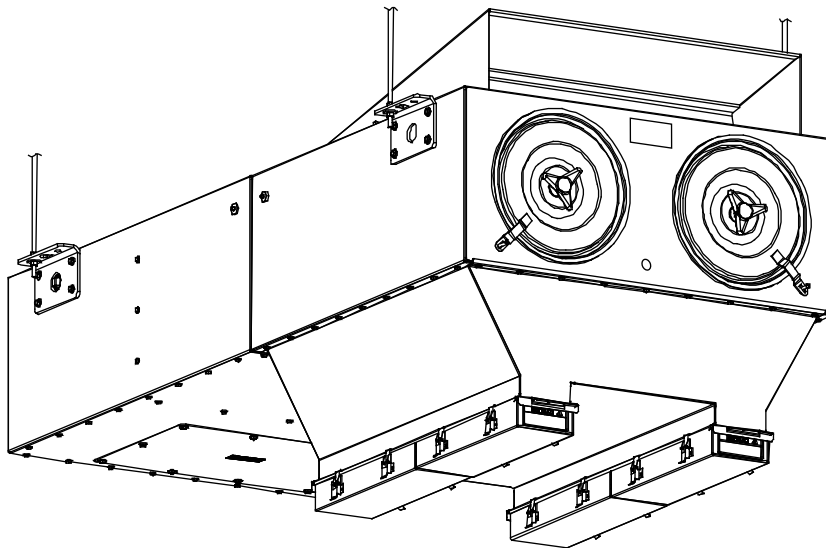

This manual is property of the owner. Leave with the unit when set-up and start-up are complete. Donaldson Company reserves the right to change design and specifications without prior notice.

Illustrations are for reference only as actual product may vary.



This is the safety alert symbol. It is used to alert you to potential personal injury hazards. Obey all safety messages that follow this symbol to avoid possible injury or death.



APPLICATION OF DUST CONTROL EQUIPMENT

Combustible materials such as buffing lint, paper, wood, metal dusts, weld fume, or flammable coolants or solvents represent potential fire and/or explosion hazards. Use special care when selecting, installing, and operating all dust, fume, or mist collection equipment when such combustible materials may be present in order to protect workers and property from serious injury or damage due to a fire and/or explosion.

Consult and comply with all National and Local Codes related to fire and/or explosion properties of combustible materials when determining the location and operation of all dust, fume, or mist collection equipment.

When combustible materials are present you must consult with an expert in fire extinguishing and/or explosion protection systems, who is also familiar with the local codes, for support and guidance on the selection and installation of an appropriate fire and/or explosion protection system.

DO NOT allow sparks, cigarettes or other burning objects to enter the hood or duct of any dust, fume, or mist collection equipment as these may initiate a fire or explosion of any combustible materials accumulated in the collector.

Portions of dust, mist, and fume-collection equipment, including the clean- and dirty-air plenums may be considered "OSHA Confined Spaces." Refer to the appropriate OSHA regulations to determine if a specific installation should be considered a confined space and if a permit program is required.

Recirculating filtered air in your facility can be a hazard. Consult with OSHA to ensure compliance with all codes regarding recirculating filtered air.

Improper operation of a dust, fume, or mist control system may contribute to conditions in the work area or facility that could result in severe personal injury and product or property damage. Check that all dust, fume, or mist collection equipment is properly selected, installed, and operated for its intended use.

This manual contains specific precautionary statements relative to worker safety. Read this manual thoroughly and comply as directed. Instruct all personnel on the safe use and maintenance procedures related to this equipment. Discuss any questions on the application, use, or maintenance of this equipment with a Donaldson Torit representative.

For optimum collector performance, use only Donaldson Torit replacement parts.

Data Sheet

Model Number _____	Serial Number _____
Ship Date _____	Installation Date _____
Customer Name _____	
Address _____	

Filter Type _____	
Accessories _____	
Other _____	

Contents

Description.....	1	Operational Checklist	12
Purpose and Intended Use	1	Filter Removal and Installation.....	12
Operation.....	2	Dust Disposal	13
Inspection on Arrival	3	Compressed Air Components.....	14
Installation Codes and Procedures	3	Split Taper™ Bushing Mounting Instructions	15
Installation.....	3	Optional Equipment.....	16
Site Selection.....	3	Hopper Assembly	16
Unit Location	3	Magnehelic® Gauge	17
Rigging Instructions.....	4	Photohelic® Gauge.....	18
Electrical Wiring.....	4	Delta P Control.....	20
Standard Equipment.....	5	Delta P Plus Control	21
Ceiling Installation.....	5	Solenoid Muffler.....	22
Electrical Connection	6	Sprinkler Head	22
Compressed Air Installation	7	Troubleshooting.....	23
Solid-State Timer Installation.....	9	Service Notes	25
Preliminary Start-Up Check	11		
Maintenance Information.....	12		

Magnehelic® and Photohelic® are registered trademarks of Dwyer Instruments, Inc.



DANGER

DANGER indicates a hazardous situation which, if not avoided, will result in death or serious injury.



WARNING

WARNING indicates a hazardous situation which, if not avoided, could result in death or serious injury.



CAUTION

CAUTION, used with the safety alert symbol, indicates a hazardous situation which, if not avoided, could result in minor or moderate injury.

NOTICE

NOTICE is used to address practices not related to personal injury that may result in damage to equipment.

Description

The AT-3000 ambient collection system is a continuous-duty collector with cartridge-style filters. The downward airflow design delivers high filtration efficiency while using less energy. Continuous-duty means no downtime. The filters are pulse-cleaned two at a time, without turning the unit off. The compact size, coupled with large-volume air handling capabilities allow this unit to be placed in a variety of sites previously inaccessible to high-efficiency dust collectors. Ceiling- or wall-mount, the AT-3000 is designed for multiple-unit applications when source capture is not practical.

Designed to increase the versatility of the unit, standard options include Magnehelic or Photohelic gauges, solenoid mufflers, and a hopper attachment for moderate to heavy load applications.

Purpose and Intended Use



Misuse or modification of this equipment may result in personal injury.

Do not misuse or modify.

The AT-3000, designed for general ventilation of weld fume, is capable of handling 2,500 to 3,000 cfm. The AT-3000 is ideal when source collection is not practical.

These collectors are designed for multiple-unit installations, positioned according to specific application parameters. A typical multiunit installation arranges the units so there is continual air movement, created by the exhaust of the one collector blowing toward the inlet of another collector. If there is no air movement, fume clouds will form. Therefore, single-unit installations are not recommended.

Note that welding on oil-laden parts or heavy production welding, especially with processes that use a flux coating or core, will shorten filter life. The cartridge plugs with the soot from the burned oil or flux and is difficult to pulse clean.



Combustible materials such as buffing lint, paper, wood, metal dusts, weld fume, or flammable coolants or solvents represent potential fire and/or explosion hazards. Use special care when selecting, installing, and operating all dust, fume, or mist collection equipment when such combustible materials may be present in order to protect workers and property from serious injury or damage due to a fire and/or explosion.

Consult and comply with all National and Local Codes related to fire and/or explosion properties of combustible materials when determining the location and operation of all dust, fume, or mist collection equipment.

Standard Donaldson Torit equipment is not equipped with fire extinguishing or explosion protection systems.

Operation

During normal operation, dust-laden air enters the unit through the dirty-air inlet. Airflow is directed downward through the filter cartridges and collects on the outside surfaces of the filter. The cartridges remove fine particulate and clean, filtered air passes through the cartridge to the clean-air plenum and discharges through the clean-air outlet.

Filter cleaning is completed using pulse-jet technology. A solid-state timer energizes a solenoid valve, causing the corresponding diaphragm valve to send a pulse of compressed air through the filter cartridge. This pulse forces the accumulated dust to fall from the cartridge and into the storage area. At the end of the pulse, the diaphragm closes, and the timer sequences to the next valve in the system.

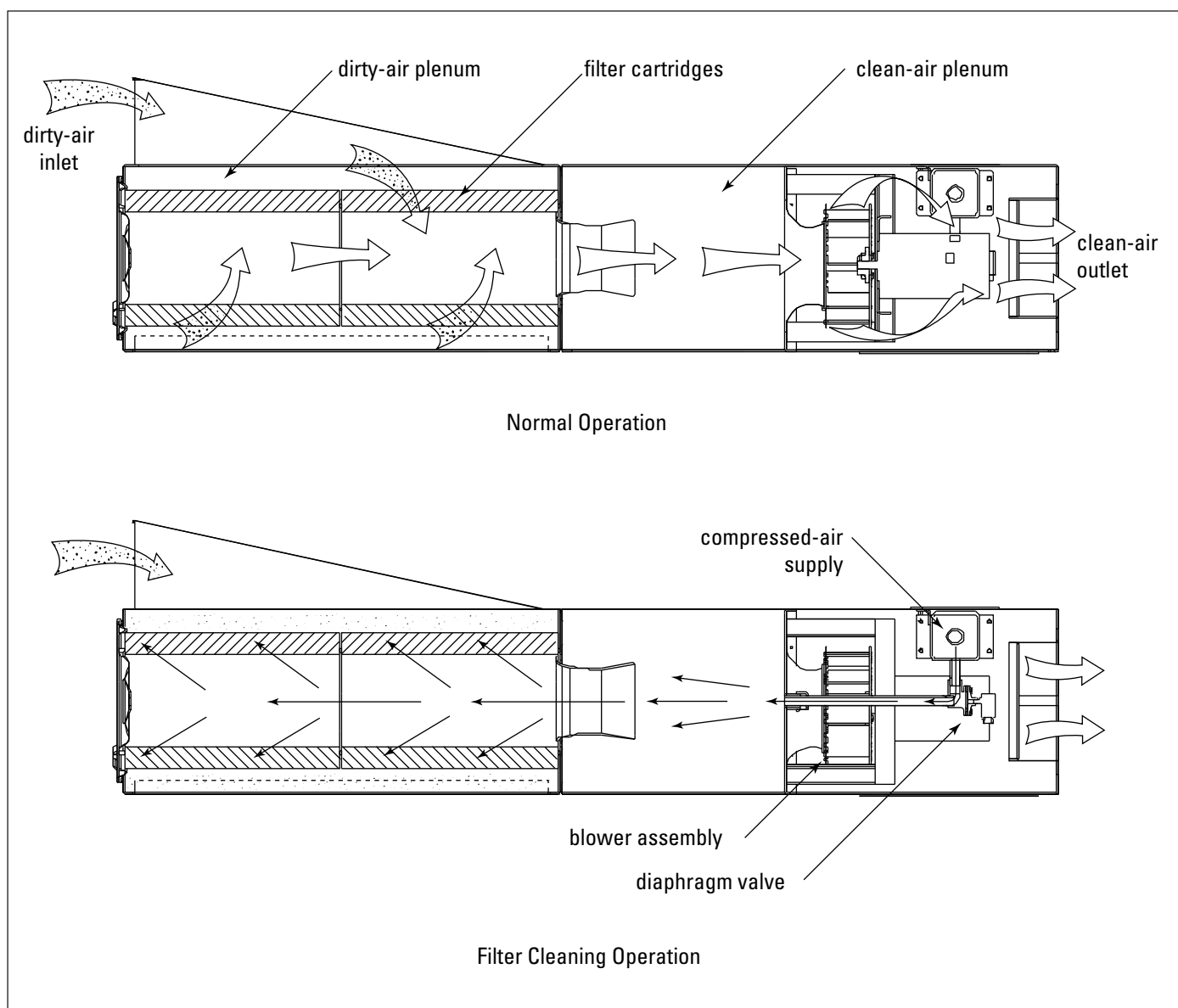

Unit Operation

Inspection on Arrival

1. Inspect unit on delivery.
2. Report any damage to the delivery carrier.
3. Request a written inspection report from the Claims Inspector to substantiate claim.
4. File claims with the delivery carrier.
5. Compare unit received with description of product ordered.
6. Report incomplete shipments to the delivery carrier and your Donaldson representative.
7. Remove crates and shipping straps. Remove loose components and accessory packages before lifting unit from truck.
8. Check for hardware that may have loosened during shipping.
9. Use caution removing temporary covers.

Installation Codes and Procedures

CAUTION

Codes may regulate recirculating filtered air in your facility.

Consult with the appropriate authorities having jurisdiction to ensure compliance with all national and local codes regarding recirculating filtered air.

Safe and efficient operation of the unit depends on proper installation.

Authorities with jurisdiction should be consulted before installing to verify local codes and installation procedures. In the absence of such codes, install unit according to the National Electric Code, NFPA No. 70-latest edition and NFPA 91 (NFPA 654 if combustible dust is present).

A qualified installation and service agent must complete installation and service of this equipment.

All shipping materials, including shipping covers, must be removed from the unit prior to, or during unit installation.

NOTICE

Failure to remove shipping materials from the unit will compromise unit performance.

Inspect unit to ensure all hardware is properly installed and tight prior to operating collector.

Installation

CAUTION

Site selection must account for wind, seismic zone, and other live-load conditions when selecting the location for all units.

Codes may regulate acceptable locations for installing dust collectors. Consult with the appropriate authorities having jurisdiction to ensure compliance with all national and local codes regarding dust collector installation.

Site Selection

1. The unit can be suspended or hung from overhead supports. The supports must be adequate to carry the live load of the unit and installation performed to reduce sway or vibration to the unit.
2. Provide clearance from heat sources and interference with utilities when selecting the location for suspended units. Reference the Specification Control Drawing shipped with the unit.

Unit Location

WARNING

Donaldson Torit equipment is not designed to support site-installed ducts, interconnecting piping, or electrical services. All ducts, piping, or electrical services supplied by others must be adequately supported to prevent severe personal injury and/or property damage.

When hazardous conditions or materials are present, consult with local authorities for the proper location of the collector.

Foundation or roof support must be capable of supporting the entire weight of the unit, plus the weight of the collected material, piping, and ductwork.

Locate the collector to ensure easy access to electrical and compressed-air connections, and routine maintenance.

If explosion protection devices are part of the system, locate the collector in accordance with the local code requirements (Example: NFPA 654).

Rigging Instructions

Suggested Installation Tools & Equipment

Clevis Pins and Clamps	Lifting Slings
Crane or Forklift	Pipe Sealant
Pipe Wrenches	Drill and Drill Bits
Screwdrivers	End Wrenches
Socket Wrenches	Spreader Bars
Large Crescent Wrench	

Hoisting Information



WARNING Failure to lift the collector correctly can result in severe personal injury or property damage.

Use appropriate lifting equipment and adopt all safety precautions needed for moving and handling the equipment.

A crane or forklift is recommended for unloading, assembly, and installation of the collector.

Location must be clear of all obstructions, such as utility lines or roof overhang.

Use all lifting points provided.

Use clevis connectors, not hooks, on lifting slings.

Use spreader bars to prevent damage to units casing.

Check the Specification Control drawing for weight and dimensions of the unit and components to ensure adequate crane capacity.

Allow only qualified crane operators to lift the equipment.

Refer to applicable OSHA regulations and local codes when using cranes, forklifts, and other lifting equipment.

Lift unit and accessories separately, and assemble after unit is in place.

Electrical Wiring



WARNING Electrical service or maintenance work must be performed by a qualified electrician and comply with all applicable national and local codes.

Turn power off and lock out electrical power sources before performing service or maintenance work.

Do not install in classified hazardous atmospheres without an enclosure rated for the application.

All electrical wiring and connections, including electrical grounding, should be made in accordance with the National Electric Code and NFPA No. 70-latest edition.

Check local ordinances for additional requirements that apply.

The appropriate wiring schematic and electrical rating must be used. See unit's rating plate for required voltage.

If the unit is not furnished with a factory-mounted disconnect, an electric disconnect switch having adequate amp capacity shall be installed in accordance with Part IX, Article 430 of the National Electrical Code and NFPA No. 70-latest edition. Check unit's rating plate for voltage and amperage ratings.

Refer to the wiring diagram for the number of wires required for main power wiring and remote wiring.

Standard Equipment

Ceiling Installation

All ceiling supports must be sized to accommodate the entire weight of the unit plus the weight of the collected material.

NOTICE

Install unit to reduce sway or vibration.

1. Use four ASTM-A36 or greater, 5/8-in threaded rods to suspend the unit. Thread a 5/8-in hex nut onto each rod at least 1 1/2-in.
2. Raise unit into position. Place a flat washer on each rod before placing the rod through the mounting or suspension bracket.
3. Place another flat washer and 5/8-in lock nut on the threaded rod under the mounting or suspension bracket. Allow 1/2-in of threaded rod to protrude through each nut.
4. Level unit in all directions by tightening the bottom lock nut.
5. When unit is level, lower the top nut to the top washer and bracket. Hold the bottom lock nut and tighten the top nut securely.

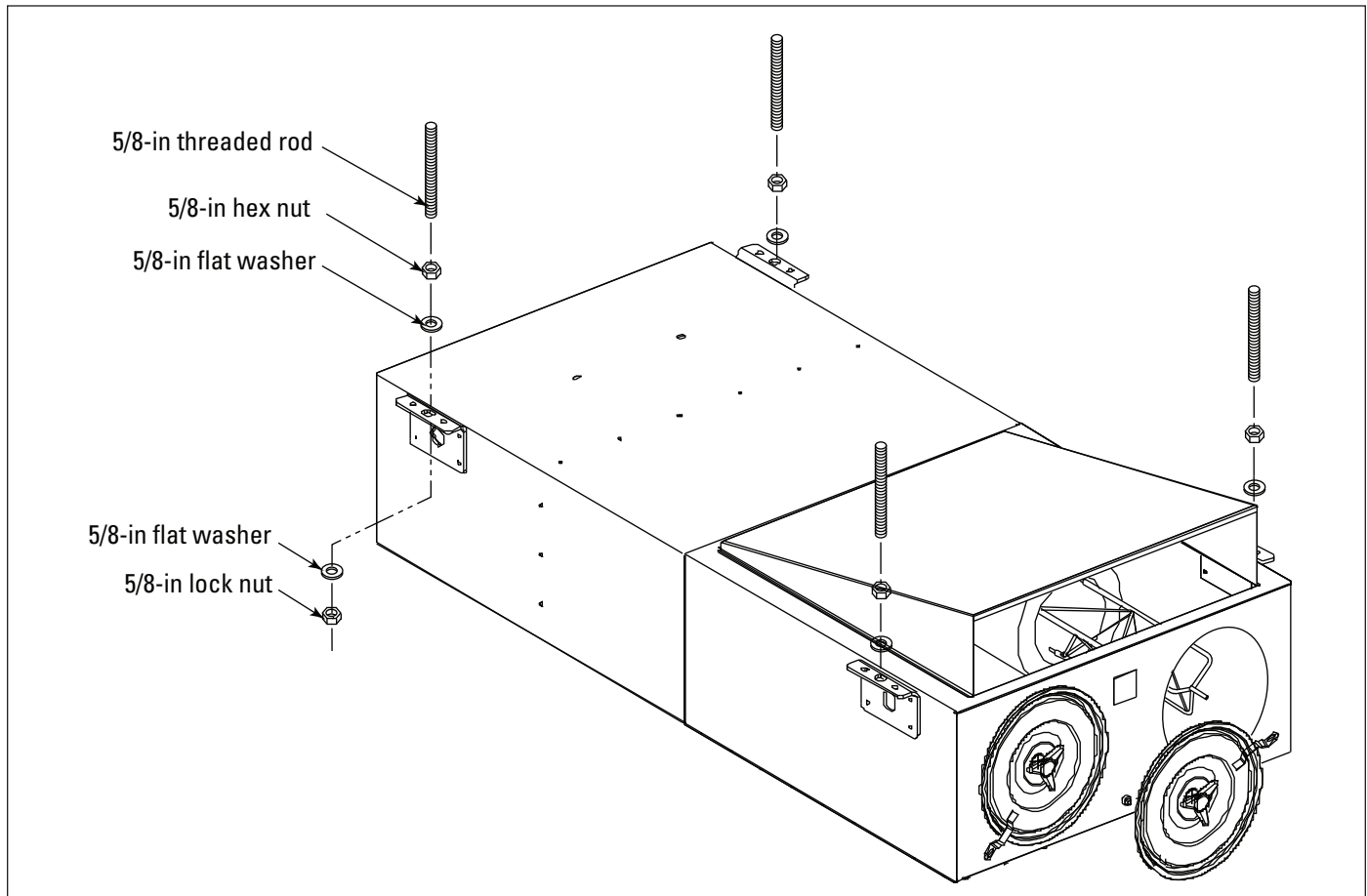

Ceiling Installation

Electrical Connection

⚠ WARNING

Electrical service or maintenance work must be performed by a qualified electrician and comply with all applicable national and local codes.

Turn power off and lock out electrical power sources before performing service or maintenance work.

Do not install in classified hazardous atmospheres without an enclosure rated for the application.

AT-3000 ambient collectors must be equipped with a customer-supplied safety disconnect with short circuit protection, contactor, and overload protection. The unit is equipped with two solenoid valves (typically 115V) that clean the filters.

The DIN connector of the solenoid valve has two power leads and a ground connection.

1. Mount the control box and starter switch in a convenient, accessible location.
2. Install conduit and wire to the unit.
3. Make the wiring connections to the fan motor, starter, solid-state timer, solenoid valves, and control switch according to the wiring diagram located inside the control box and the instructions on the motor decal. In grounded systems, connect neutral to control box to Terminal L2 on the terminal board.

NOTICE

All electrical components must be sized for the supply voltage and motor horsepower.

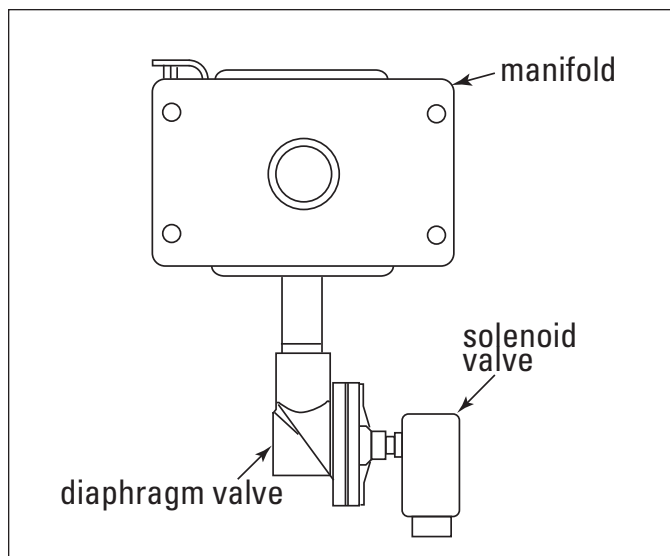

Solenoid Valve

Compressed Air Installation

WARNING

Turn compressed-air supply OFF and bleed lines before performing service or maintenance work.

A safety exhaust valve should be used to isolate the compressed air supply. The safety exhaust valve should completely exhaust downstream pressure when closed and include provisions to allow closed-position locking.

NOTICE

Do not set compressed-air pressure above 100-psig.

Component damage can occur.

All compressed air components must be sized to meet the maximum system requirements of 90-psig supply pressure.

The compressed-air supply must be oil and moisture free. Contamination in the compressed air used to clean filters will result in poor cleaning, cleaning valve failure or poor collector performance.

Purge compressed-air lines to remove debris before connecting to the unit's compressed-air manifold.

1. Remove the plastic pipe plug from the unit's air manifold and connect the compressed-air supply line. Use thread-sealing tape or pipe sealant on all compressed-air connections.
2. Install a customer-supplied shut-off valve, bleed-type regulator with gauge, filter, and automatic condensate valve in the compressed-air supply line.



WARNING

Turn compressed-air supply OFF and bleed lines before performing service or maintenance work.

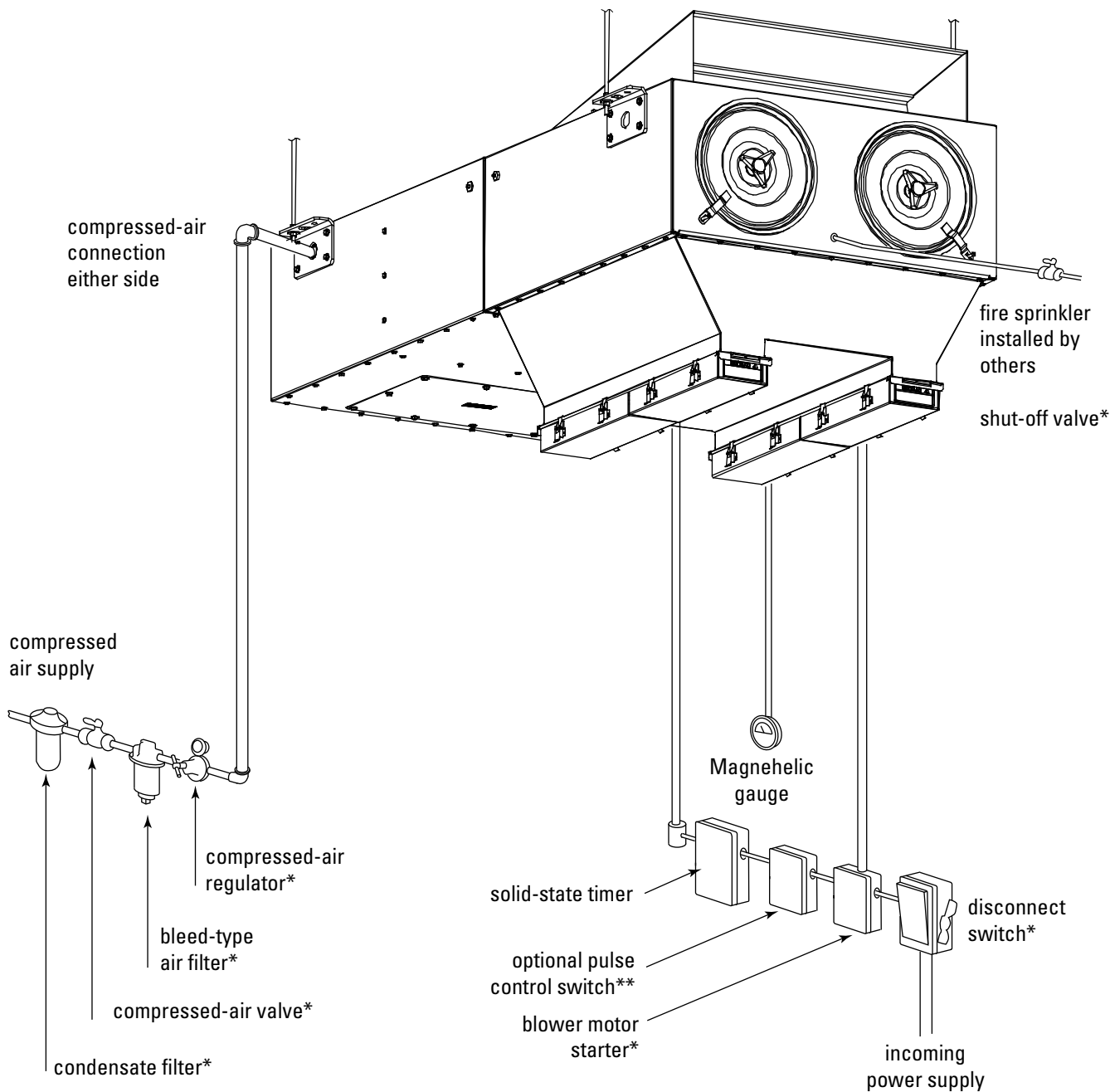

*customer-supplied

** can be a Photohelic, toggle, ON/OFF, or other control-type switch

Compressed Air Installation

Solid-State Timer Installation

WARNING

Electrical service or maintenance work must be performed by a qualified electrician and comply with all applicable national and local codes.

Turn power off and lock out electrical power sources before performing installation, service, or maintenance work.

Do not install in classified hazardous atmospheres without an enclosure rated for the application.

The unit is equipped with 115-V solenoid valves that control the pulse-cleaning valves, which clean the filters. Wire the solenoids to the solid-state timer following the wiring diagram supplied with the unit. Filter life and cleaning operation will be affected if not wired correctly.

Pulse Control Switch, 1TGS

Closing this switch applies power to the timer control circuit, which operates in parallel with the blower starter's low-voltage coil. On blower start-up, power is supplied to the timer and the preset OFF time is initiated. At the end of the OFF time, the timer energizes the corresponding solenoid valve to provide the ON time cleaning pulse for one diaphragm valve and then steps to the next until all filters have been cleaned. The cycle continues until the pulse-control switch opens. Check that the program pin on the solid-state timer board is set to the number of solenoid valves controlled.

Input

Order dependent. See wiring diagram.

Output Solenoids

The load is carried and turned ON and OFF by the 200 watt maximum-load-per-output solid-state switch.

Pulse ON Time

Factory set at 100-milliseconds, or 1/10-second.

NOTICE

Do not adjust pulse ON time unless the proper test equipment is available. Too much or too little ON time can cause shortened filter life.

Pulse OFF Time

Factory set at 10-seconds, adjustable from 1 to 1.5-second minimum to maximum 60 to 66-second.

Operating Temperature Range

-20° F to 130° F

Transient Voltage Protection

50 kW transient volts for 20-millisecond duration once every 20 seconds, 1% duty cycle.

Solenoid Valves

Order dependent. See wiring diagram.

Compressed-Air

Set compressed-air supply at 90-psig. The timer is factory set to clean one set of filters every 10-seconds.

NOTICE

Do not increase supply pressure above 100-psig. Component damage can occur.

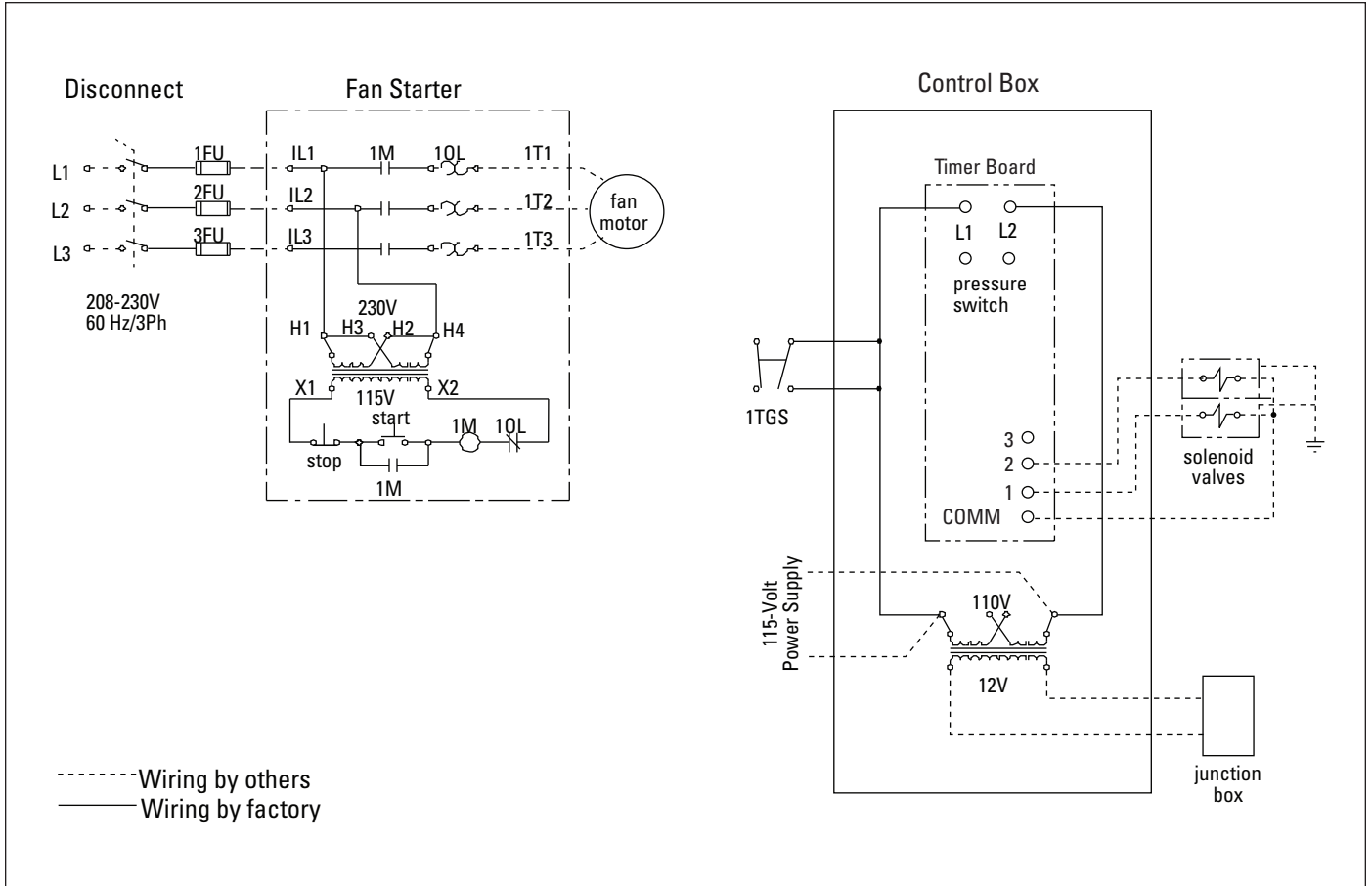

Typical Solid-State Timer Wiring

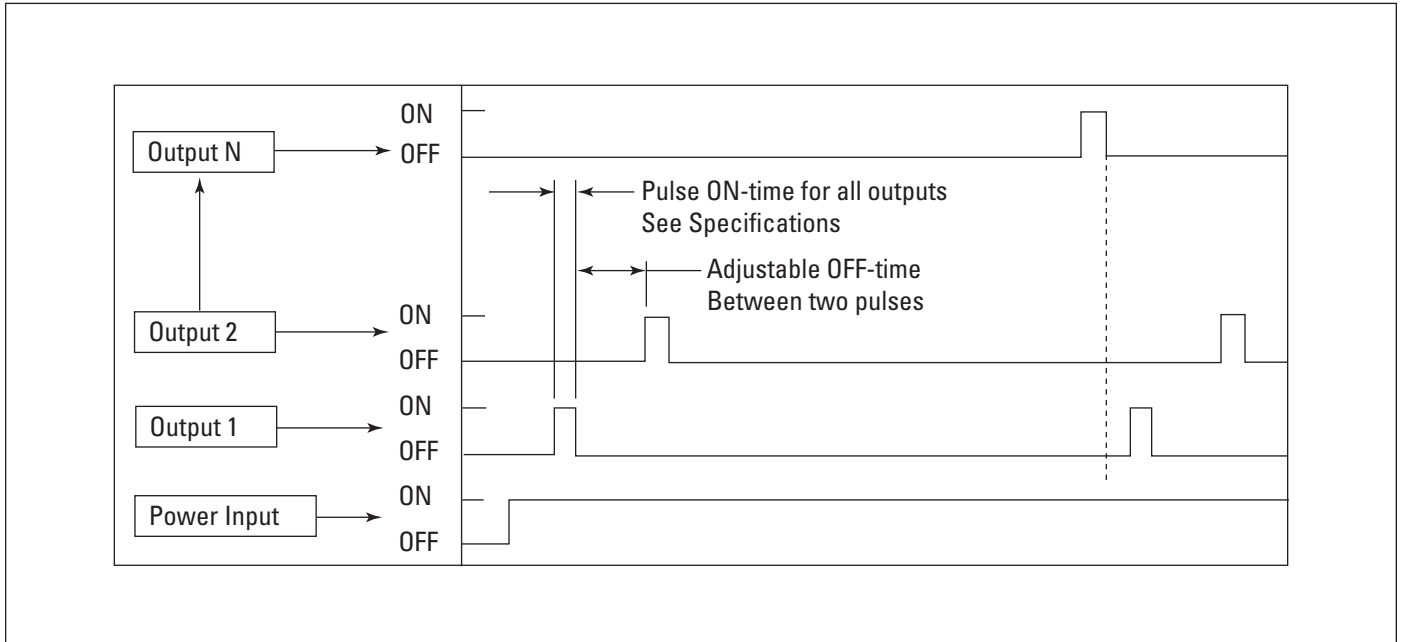

Typical Operating Logic Diagram

Preliminary Start-Up Check

WARNING

Electrical work during installation must be performed by a qualified electrician and comply with all applicable national and local codes.

Turn power off and lock out electrical power sources before performing service or maintenance work.

Turn compressed air supply OFF and bleed lines before performing service or maintenance work.

Check that the collector is clear and free of all debris before starting.

Do not install in classified hazardous atmospheres without an enclosure rated for the application.

1. Check all electrical connections for tightness and contact.
2. Motor and fan should be wired for clockwise rotation when viewed from the back of the motor.

To reverse rotation, single-phase power supply:
Follow manufacturer's instructions on the motor's nameplate.

To reverse rotation, three-phase power supply:
Turn electrical power OFF at source and switch any two leads on the output-side of the fan-motor starter.

WARNING

Do not interchange a power lead with the ground wire. Severe personal injury or equipment damage may result.

3. All access panels should be sealed and secure.
4. Check that the storage container is sealed, if equipped.
5. Check for and remove all loose items in or near the inlet and outlet of the unit.
6. Check that all remote controls are wired into the control system, and all service switches are in the OFF position.
7. Check that all optional accessories are installed properly and secured.
8. Turn power ON at source.

9. Turn the compressed-air supply ON. Adjust pressure regulator 90-psig.
10. Check the operation of the solenoid valves by turning the pulse control switch ON. The solenoid valves should open and close continuously at preset ON and OFF times.
11. Turn the blower fan motor ON.

WARNING

Do not look into fan outlet to determine rotation. View the fan rotation through the back of the motor.

Check that the exhaust plenum is free of tools or debris before checking blower fan rotation.

Stand clear of exhaust to avoid personal injury.

12. Adjust airflow with the exhaust damper.

NOTICE

Excess airflow can shorten filter life, cause electrical system failure and blower motor failure.

Maintenance Information

Instruct all personnel on safe use and maintenance procedures.

WARNING

Use proper equipment and adopt all safety precautions needed

for servicing equipment. Electrical service or maintenance work must be performed by a qualified electrician and comply with all applicable national and local codes.

Turn power off and lock out electrical power sources before performing service or maintenance work.

Do not install in classified hazardous atmospheres without an enclosure rated for the application.

Turn compressed air supply OFF and bleed lines before performing service or maintenance work.

NOTICE

Do not set compressed-air pressure above 100-psig.

Component damage can occur.

All compressed air components must be sized to meet the maximum system requirements of 90-100 psig supply pressure.

The compressed-air supply must be oil and moisture free. Contamination in the compressed air used to clean filters will result in poor cleaning, cleaning valve failure, or poor collector performance.

Purge compressed air lines to remove debris before connecting to the unit's compressed air manifold.

Operational Checklist

1. Monitor the physical condition of the collector and repair or replace any damaged components.

Routine inspections will minimize downtime and maintain optimum system performance. This is particularly important on continuous-duty applications.

Periodically check the compressed air components and replace compressed air filters. Drain moisture

following the manufacturer's instructions. With the compressed air supply ON, check the cleaning valves, solenoid valves, and tubing for leaks. Replace as necessary.

2. Monitor pressure drop across filters.

Abnormal changes in pressure drop indicate a change in operating conditions and possibly a fault to be corrected. For example, prolonged lack of compressed air will cause an excess build-up of dust on the filters resulting in increased pressure drop. Cleaning off-line with no flow usually restores the filters to normal pressure drop.

3. Monitor exhaust.
4. Monitor dust disposal.

Filter Removal and Installation

WARNING

Use proper safety and protective equipment when removing

contaminants and filters.

Dirty filters may be heavier than they appear.

Use care when removing filters to avoid personal injury.

Filter Removal

1. Turn power to unit OFF.
2. Remove the filter access covers by turning the knob counterclockwise.
3. Break the seal between the filter cartridge and the sealing surface.
4. Slowly rotate the cartridge 1/2-turn to remove dust that may have accumulated on the top of the filter.
5. Slide the filter out the access port along the suspension yoke.
6. Dispose of properly.

7. Clean the sealing surface with damp cloth.

NOTICE

Clean dust from gasket sealing area to ensure a positive filter gasket seal.

8. Check for an accumulation of dust in the storage area and empty as necessary.

Filter Installation

1. Slide the new filter cartridge onto each suspension yoke.

NOTICE

Insert the filter, gasket end first.

2. Wipe cover gaskets clean and replace covers by turning the knob clockwise.

NOTICE

Tighten access covers securely by hand. Gaskets must be compressed to seal properly.

Inspect and replace any covers with damaged or missing gaskets. Failure to do may result in leakage in the collector.

3. Turn electrical power and compressed air supply ON before starting unit.

Dust Disposal

Standard Unit

1. Open the filter-access covers and remove the filter cartridges. See Filter Removal and Replacement.
2. Remove the dust with a dry sweeper or brush and dispose of properly.
3. Replace filters and close filter-access covers securely. See Filter Removal and Replacement.
4. Turn electrical power and compressed air supply ON before starting unit.

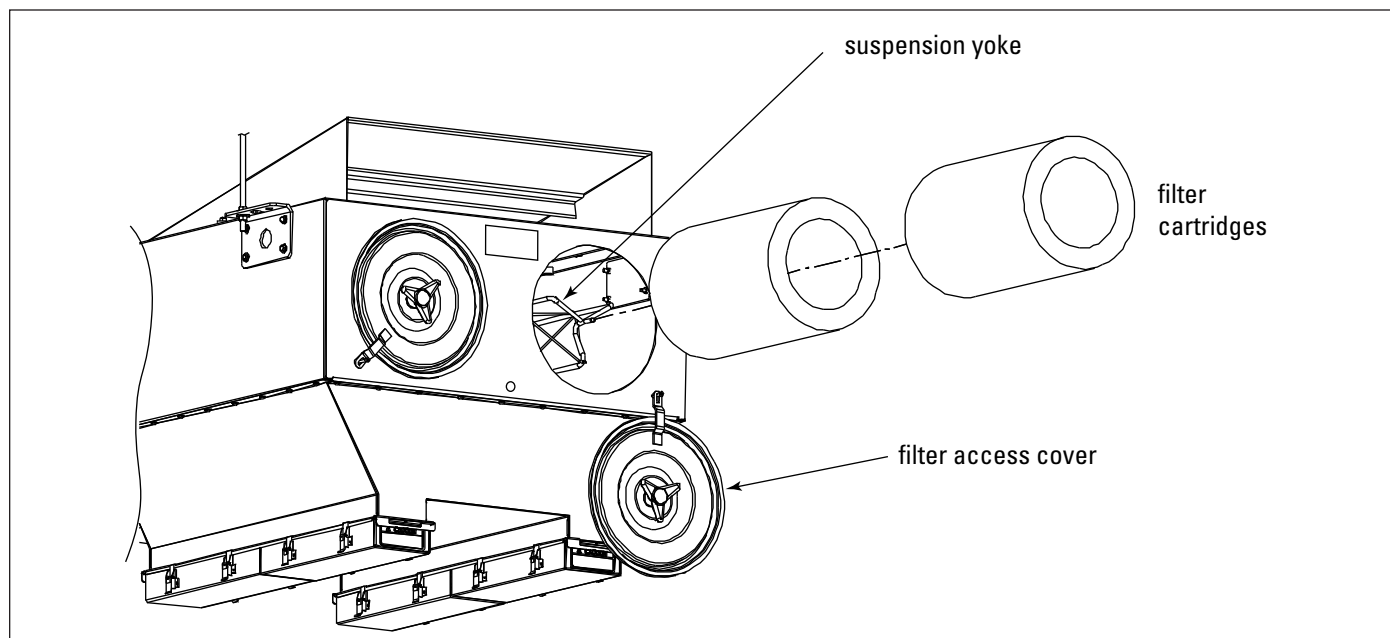

Filter Removal and Replacement

Hopper Unit

1. Open the filter-access covers and remove the filter cartridges. See Filter Removal and Replacement.
2. Sweep or brush hopper walls.
3. Replace filters and close filter-access covers securely. See Filter Removal and Replacement.
4. Remove the dustpans and dispose of dust properly. Empty and clean the dust pans every other day in heavy dust-load applications, and every week in light-to-medium applications.

NOTICE

Full dust pans can weigh up to 45-lbs. Use care when removing.

5. Inspect the gasket for wear that could cause a leak during operation. Replace if necessary.
6. Clean the baffle with a dry brush or dry putty knife.
7. Inspect the draw latches for breaks, deformities, or wear and replace as necessary.
8. Reinstall the dust pans.

9. Turn electrical power and compressed air supply ON before starting unit.

Compressed Air Components

WARNING

Turn compressed-air supply OFF and bleed lines before performing service or maintenance work.

NOTICE

Do not set compressed-air pressure above 100 psig. Component damage can occur.

1. Periodically check the compressed air components and replace compressed-air filter.
2. Drain moisture following the manufacturer's instructions.
3. With the compressed-air supply ON, check the cleaning valves, solenoid valves, and tubing for leaks. Replace as necessary.

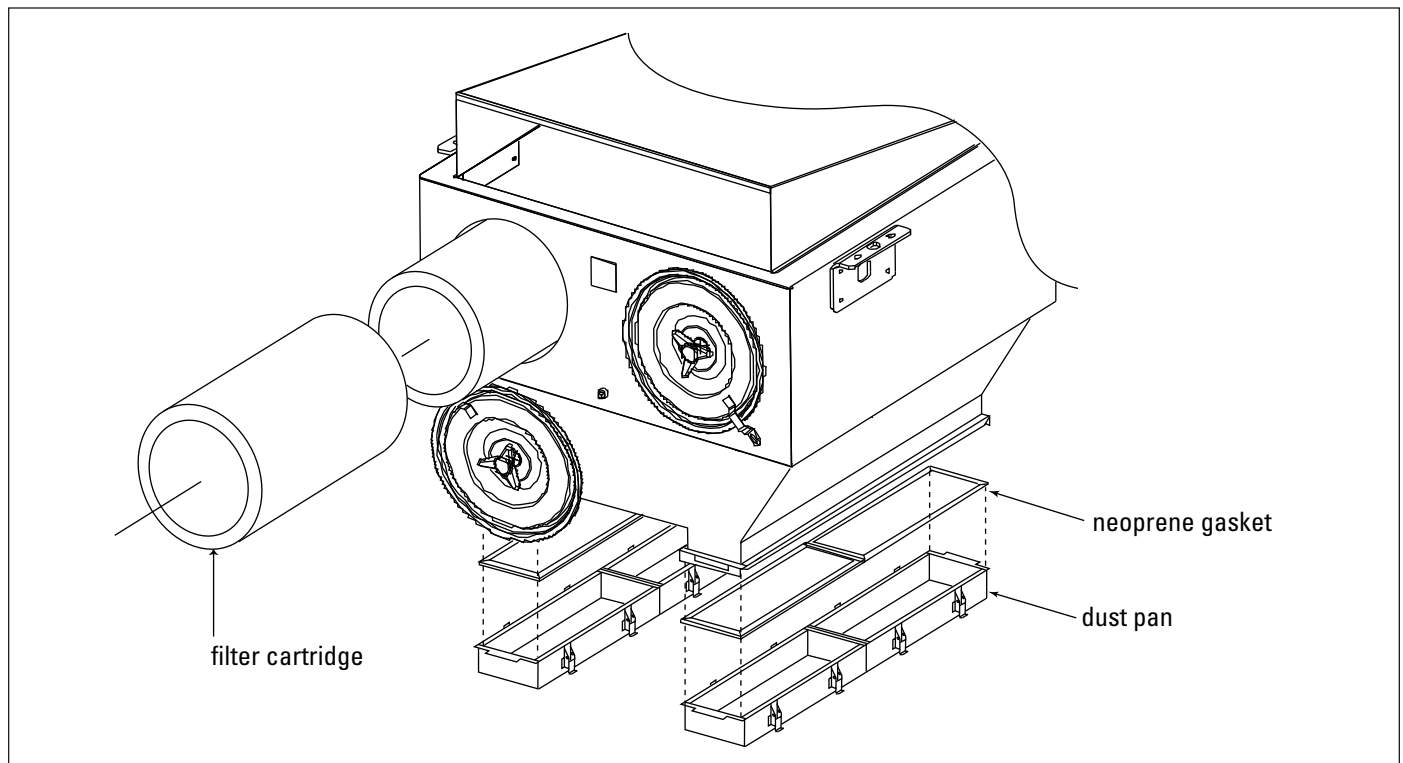

Dust Disposal

Split Taper™ Bushing Mounting Instructions

Many fans are furnished with split taper bushings for mounting the impeller to the shaft. When properly assembled, the bushings grip the hub with a positive clamping action.

1. Bushel barrel and bore of impeller are tapered to ensure concentric mounting and a true running propeller.
2. Capscrews, when tightened, lock bushing in propeller. Use special plated capscrews and nylock nuts.

Bushing No.	Bolt Size	Torque Ft-Lbs
QT/QH/L/H	1/4-20	7-1/2

3. Bushing is split so that when the locking capscrews force bushing into tapered bore, the bushing grips the shaft with a positive clamping fit. This will withstand vibration and heavy loads without being loosened.
4. Impeller and bushing assembly is keyed to the shaft and held in place by compression, which adds driving strength.

Note: Before assembly, ensure shaft and keyway are clean and smooth. Check key size with both shaft and bushing keyway.

5. To assemble, insert the capscrews through the clearance holes in the bushing and install bushing loosely into the impeller. Do not press or drive. Start capscrews by hand, turning them just enough to engage threads in the nylock nut. Do not use a wrench at this time. The bushing should be loose enough in the propeller to move freely. Slide impeller and bushing assembly onto shaft, allowing adequate clearance for shaft end play to prevent friction. Fit key into keyway. Do not force impeller and bushing onto shaft. If it does not go on easily, check shaft, bushing, and key sizes once again.

CAUTION

Do not attempt to pull bushing flange flush with hub end.

There should be a clearance which varies approximately 3/16-in to 1/4-in with the busing size when tightened. This is not a locating dimension.

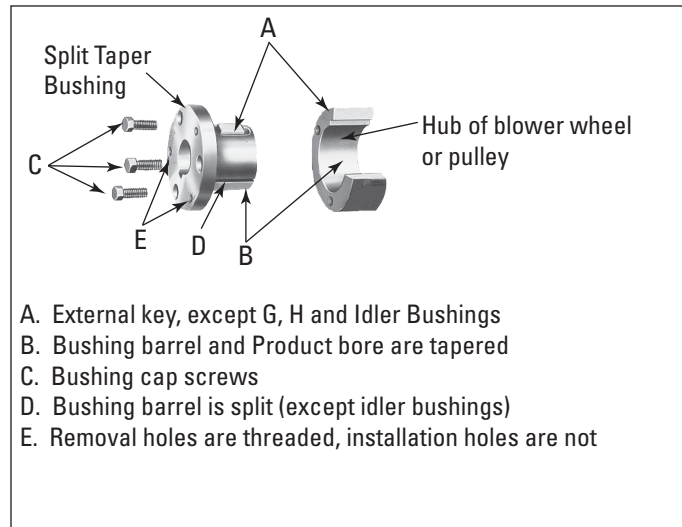

- A. External key, except G, H and Idler Bushings
- B. Bushing barrel and Product bore are tapered
- C. Bushing cap screws
- D. Bushing barrel is split (except idler bushings)
- E. Removal holes are threaded, installation holes are not

Split Taper Bushing Installation

Tighten capscrews gradually and evenly with wrench similar to mounting an automobile wheel. Rotate a quarter turn on each capscrew successively until all capscrews are tight. These capscrews force the taper bushing into the hub, which in turn compresses the bushing onto the shaft. This makes a positive clamping fit. The torque must not exceed the value specified in the table.

Impeller Assembly Removal

1. Remove all capscrews from impeller and hub assembly.
2. Insert capscrews into the threaded holes in the bushing flange.
3. Tighten each bolt in quarter of a turn increments to push the impeller off the bushing. This forces the bushing loose from the propeller hub and releases the compression so that the entire assembly will slide from the shaft.
4. Pull the bushing off the shaft.

Note: If the assembly has been in place sometime it may be necessary to use a wheel puller to remove the bushing. Never use a wheel puller on the impeller.

Optional Equipment

Hopper Assembly

WARNING

Failure to lift the collector correctly can result in severe personal injury or property damage.

Use appropriate lifting equipment and adopt all safety precautions needed for moving and handling the equipment.

A crane or forklift is recommended for unloading, assembly, and installation of the collector.

Location must be clear of all obstructions, such as utility lines or roof overhang.

Standard units ship with a standard panel on the bottom of the dirty-air plenum. If the optional hopper is ordered, the unit is shipped with a protective shipping cover on the dirty-air plenum.

1. Remove the bottom panel or protective shipping cover from the dirty-air plenum.
2. Apply 1/4-in diameter, rope-type sealant to the hopper flange.
3. Using a crane or forklift, lift the hopper into position under the unit and secure with thirty-six 1/4-20 UNC x 3/4-in thread-forming screws supplied.

NOTICE

Do not over tighten thread-forming screws.

4. Remove lifting equipment.

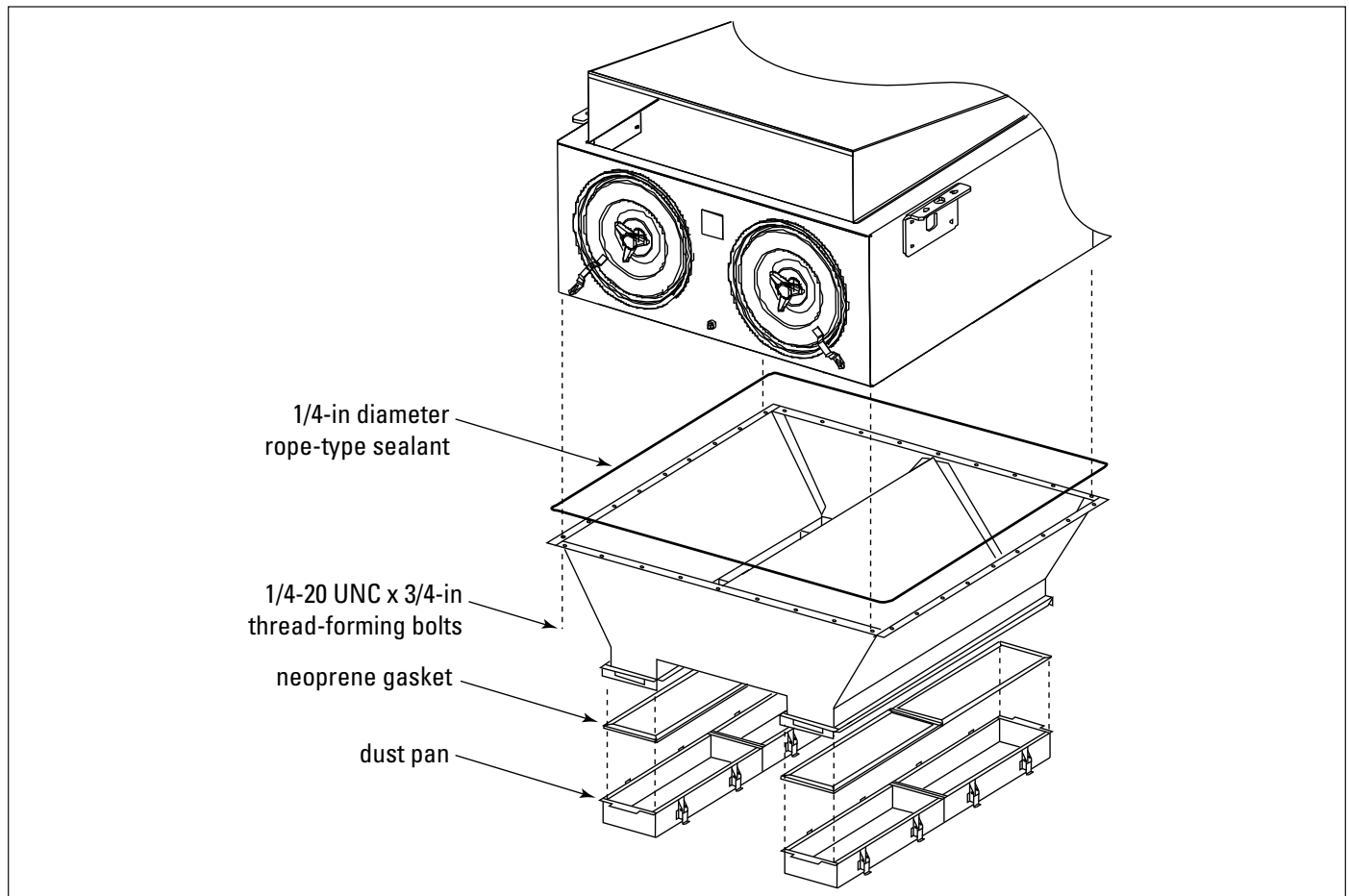

Hopper Assembly

Magnehelic® Gauge

The Magnehelic is a differential pressure gauge used to measure the pressure difference between the clean- and dirty-air chambers and provides a visual display of filter change requirements. The high-pressure tap is located in the dirty-air plenum and the low-pressure tap is located in the clean-air plenum.

1. Choose a convenient, accessible location on or near the unit for mounting that provides the best visual advantage.
2. Plug the pressure ports on the back of the gauge using two, 1/8-in NPT pipe plugs supplied. Install two, 1/8-in NPT male adapters supplied with the gauge into the high- and low-pressure ports on the side of the gauge.
3. Attach the mounting bracket using three, #6-32 x 1/4-in screws supplied.
4. Mount the gauge and bracket assembly to the supporting structure using two, self-drilling screws.
5. Thirty-five feet of plastic tubing is supplied and must be cut in two sections. Connect one section of tubing from the gauge's high-pressure port to the pressure fitting located in the dirty-air plenum. Connect remaining tubing from the gauge's low-pressure port to the fitting in the clean-air plenum. Additional tubing can be ordered from your representative.
6. Zero and maintain the gauge as directed in the manufacturer's Operating and Maintenance Instructions provided.

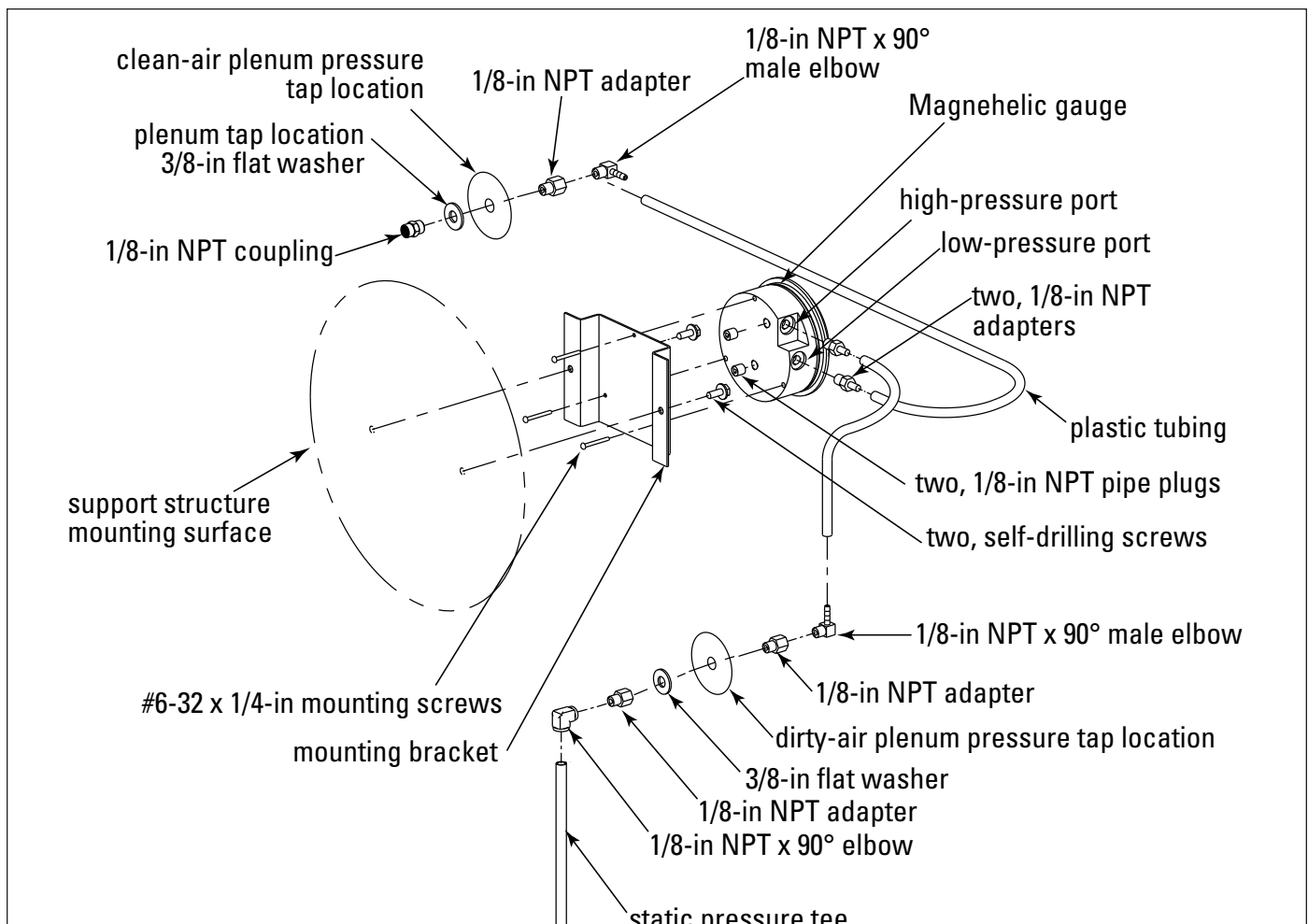

Magnehelic Gauge Assembly

Photohelic® Gauge

WARNING

Electrical service or maintenance work must be performed by a qualified electrician and comply with all applicable national and local codes.

Turn power off and lock out electrical power sources before performing service or maintenance work.

Do not install in classified hazardous atmospheres without an enclosure rated for the application.

The Photohelic combines the functions of a differential pressure gauge and a pressure-based switch. The gauge function measures the pressure difference between the clean- and dirty-air plenum and provides a visual display of filter condition. The high-pressure tap is located in the dirty-air plenum and a low-pressure tap is located in the clean-air plenum. The pressure-based switch function provides high-pressure ON and low-pressure OFF control of the filter cleaning system.

1. Choose a convenient, accessible location on or near the unit for mounting that provides the best visual advantage.
2. Mount the gauge to the remote panel or door using the mounting ring, retaining ring, and four #6-32 x 1 1/4-in screws. Do not tighten screws. Connect two, 1/8-in NPT x 1/4-in OD male adapters to the gauge's high- and low-pressure ports. Tighten screws.
3. On the back of the gauge, remove four #6-32 x 5/16-in screws and plastic enclosure. Set aside. Add two jumper wires supplied by customer. Remove the jumper from the pressure switch located on the timer board, if equipped. Using the 3/4-in conduit opening, wire the gauge as shown. Reassemble and fasten enclosure securely.
4. Thirty-five feet of plastic tubing is supplied and must be cut in two sections. Connect one section of tubing from the gauge's high-pressure port to the pressure fitting located in the dirty-air plenum. Connect remaining tubing from the gauge's low-pressure port to the fitting in the clean-air plenum. Additional tubing can be ordered from your representative.
5. Zero and maintain the gauge as directed in the manufacturer's Operating and Maintenance Instructions provided.

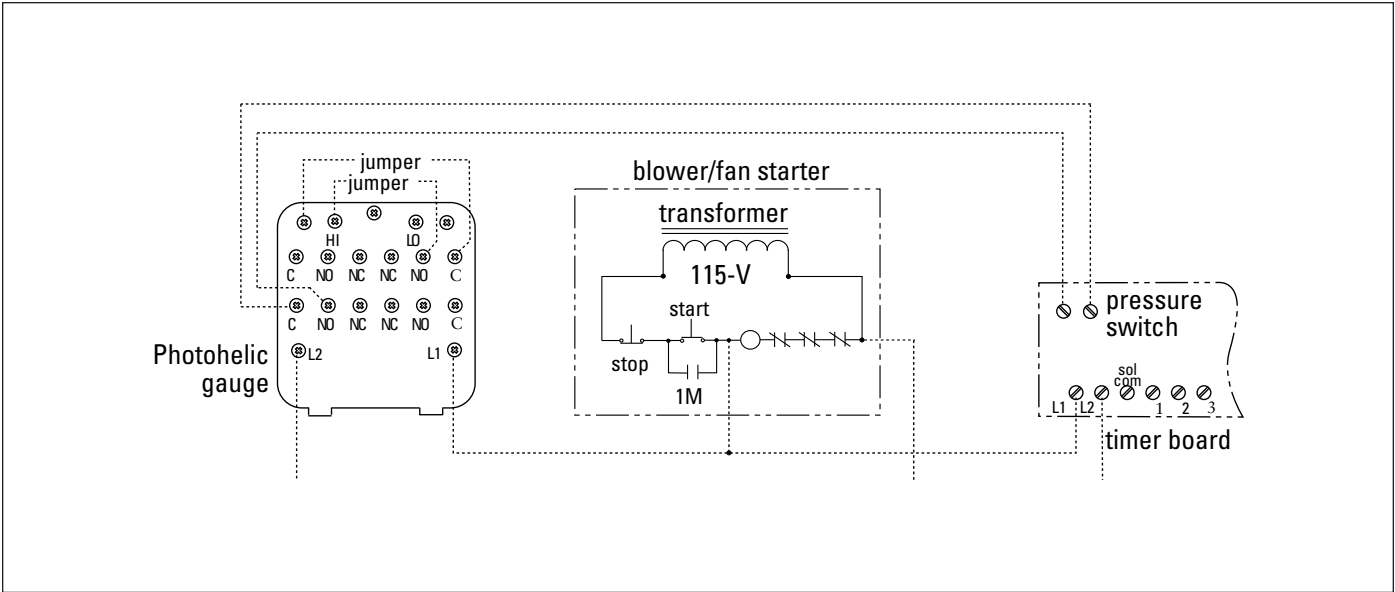

Photohelic Gauge Wiring

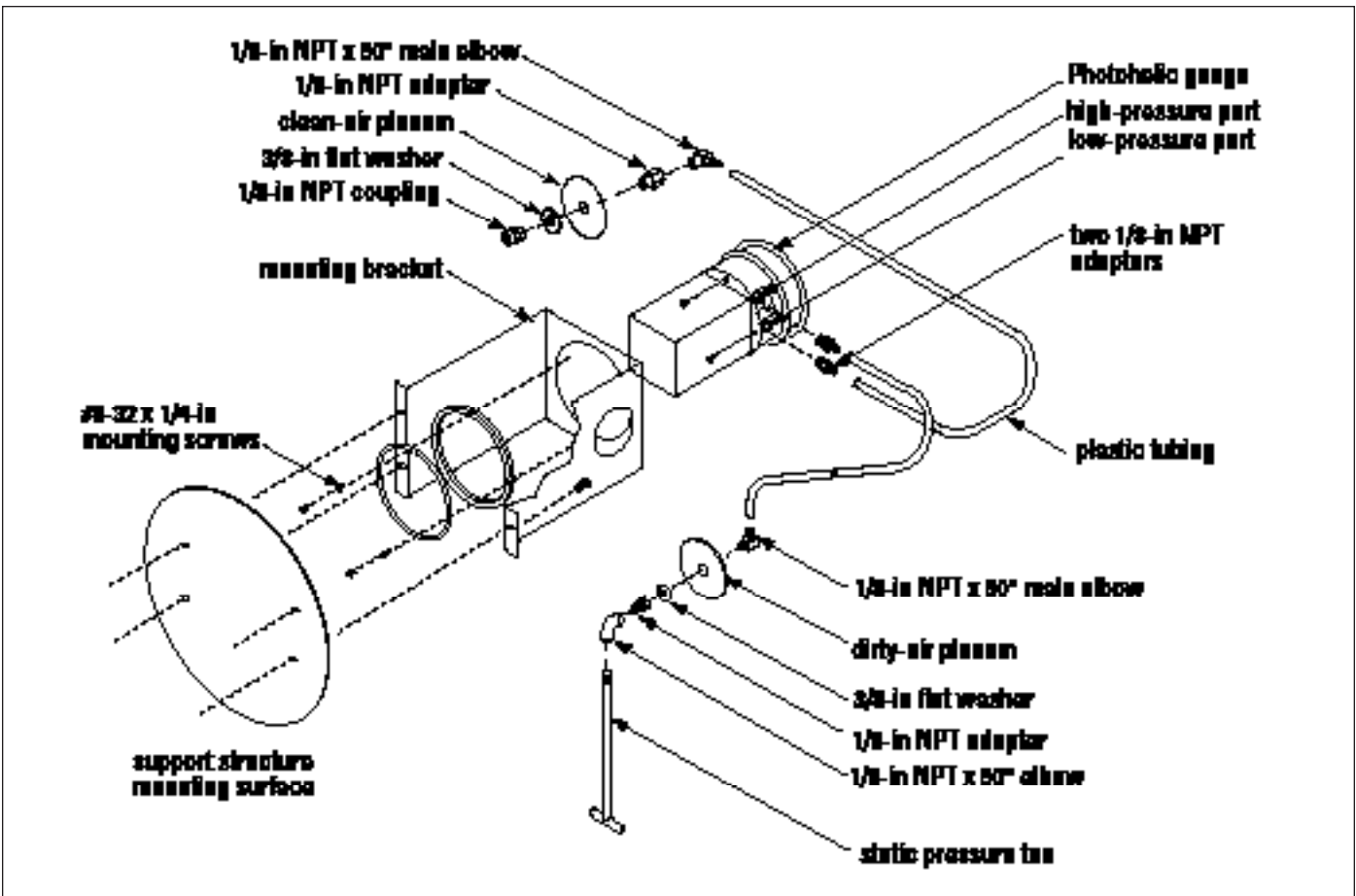

Photohelic Gauge Installation

Delta P Control

Description

The Delta P Controller monitors the differential pressure between the clean and dirty air plenums, providing a visual display of the filter condition. When combined with a pulse timer, it controls the pressure drop by turning the cleaning mechanism On and Off at the chosen limits. There are three (3) set points: High Pressure On, Low Pressure Off, and Alarm. The first two, High Pressure On and Low Pressure Off, control the filter cleaning system. The third, Alarm, provides a relay output to activate an external alarm supplied by others.

Operation

Normal

The Delta P Controller monitors the pressure in the clean and dirty air plenums while the unit is running. The blower draws air through the filters, creating a pressure drop. The Delta P Controller measures the pressure drop and provides a visual display in inches water gauge or metric (SI) units of daPa.

Filter Cleaning

When the pressure drop across the filters reaches the High Pressure On setpoint, the controller closes an output relay allowing a timer to trigger the cleaning valves sequentially. When the controller senses that the pressure drop has decreased to the Low Pressure Off setpoint, the relay opens and the cleaning cycle stops. This sequence continues as long as the collector is in use, maintaining the pressure drop within a narrow range.

Alarm

The Alarm setpoint is set to a higher setting than the High Pressure On setpoint used to start the filter cleaning cycle. It indicates situations when the cleaning system cannot reduce the pressure drop due to cleaning system failure, lack of compressed air, or the end of the filter's useful life. There is a time delay prior to setting the Alarm to prevent nuisance trips. The Delta P Controller also provides an input connection for a remote alarm reset.

For complete information, see the most current version of the Delta P Installation, Operation, and Maintenance manual.



Delta P Control Display

Delta P Plus Control

Description

The Delta P Plus Controller monitors the differential pressure between the clean and dirty air plenums, providing a visual display of the filter condition. When combined with a pulse timer, it controls the pressure drop by turning the cleaning mechanism On and Off at the chosen limits. There are three (3) set points: High Pressure On, Low Pressure Off, and Alarm. The first two, High Pressure On and Low Pressure Off, control the filter cleaning system. The third, Alarm, provides a relay output to activate an external alarm supplied by others.

The user can program the Delta P Plus Controller to pulse while the collector is running, to maintain a relatively constant pressure drop across the filters, pulse only after the collector is shut down (after-shift cleaning), or a combination of both, cleaning while running as well as end of the shift.

Operation

Normal

The Delta P Plus Controller monitors the pressure on both sides of the tubesheet while the unit is running. As air flows through the filters, the resistance of the media and collected dust creates a pressure difference or "drop" between the dirty and clean air plenums. The Delta P Plus Controller measures the pressure drop and provides a visual display in inches water gauge or metric (SI) units of daPa.

Filter Cleaning

The Delta P Plus Controller offers three filter cleaning options.

1. **Differential Pressure Cleaning (DFF)** - When the pressure drop across the filters reaches the Controller's High Pressure On setpoint, the Controller closes an output relay allowing a sequential timer to trigger the cleaning valves. When the Controller senses that the pressure drop has decreased to the Low Pressure Off setpoint, the relay opens and the cleaning cycle stops. This sequence continues as long as the collector is in use, maintaining the pressure drop within a narrow range.

2. **Downtime Cleaning (DTC)** - The Delta P Plus Controller monitors the collection system. When the pressure drop exceeds the Low Pressure Off set point and then approaches zero again, the Delta P Plus Controller runs a delay timer to allow the blower to come to a stop and then engages the cleaning mechanism for a preselected time.
3. **Combined Differential and Downtime Cleaning (ALL)** - The Delta P Plus Controller combines the two functions described above; maintaining the pressure drop in a narrow band and downtime cleaning the filters when the collector is shut down. The downtime cleaning function can be toggled On or Off from the keyboard.

Alarm

The Alarm setpoint is set to a higher setting than the High Pressure On used to start the filter cleaning cycle. It indicates situations when the cleaning system cannot reduce the pressure drop due to cleaning system failure, lack of compressed air, or the end of the filter's useful life. There is a time delay prior to setting the Alarm to prevent nuisance trips. The Delta P Plus Controller also provides an input connection for a remote Alarm reset.

For complete information, see the most current version of the Delta P Plus Installation, Operation, and Maintenance manual.



Delta P Plus Control Display

Solenoid Muffler

Solenoid mufflers help reduce the noise created by pulse cleaning.

Sprinkler Head

One 3/4-in horizontal sprinkler head is factory-installed on the dirty-air plenum. Install piping and a customer-supplied shut-off valve to control the water supply. Inspect sprinkler head monthly for accumulated fume contamination that can cause the sprinkler to malfunction. Change the sprinkler head annually.

Troubleshooting

Problem	Probable Cause	Remedy
Blower fan and motor do not start	Improper motor wire size	Rewire using the correct wire gauge as specified by national and local codes.
	Not wired correctly	Check and correct motor wiring for supply voltage. See motor manufacturer's wiring diagram. Follow wiring diagram and the National Electric Code.
	Unit not wired for available voltage	Correct wiring for proper supply voltage.
	Input circuit down	Check power supply to motor circuit on all leads.
	Electrical supply circuit down	Check power supply circuit for proper voltage. Check for fuse or circuit breaker fault. Replace as necessary.
	Overload relay tripped	Reset. Check amp draw on motor leads.
	Defective overload heater or overload assembly	Replace as necessary.
Blower fan and motor start, but do not stay running	Incorrect motor starter installed	Check for proper motor starter and replace if necessary.
	Access doors are open or not closed tight	Close and tighten access doors. See Filter Replacement.
	Electrical circuit overload	Check that the power supply circuit has sufficient power to run all equipment.
Clean-air outlet discharging dust	Filters not installed correctly	See Filter Replacement.
	Filter damage, dents in the end caps, gasket damage, or holes in media	Replace filters as necessary. Use only genuine Donaldson replacement parts. See Filter Replacement.
	Access doors are open or not closed tight	Close and tighten access doors.
Insufficient airflow	Fan rotation backwards	Proper fan rotation is clockwise from the top of the unit. The fan can be viewed through the back of the motor. See Preliminary Start-Up Check.
	Access doors open or not closed tight	Check that all access doors are in place and secured. Check that the hopper discharge opening is sealed and that dust container is installed correctly.
	Fan exhaust area restricted	Check fan exhaust area for obstructions. Remove material or debris. Adjust damper flow control.
	Filters need replacement	Remove and replace using genuine Donaldson replacement filter packs. See Filter Replacement.

Problem	Probable Cause	Remedy
Insufficient airflow continued	Lack of compressed air	See Rating and Specification Information for compressed air supply requirements.
	Pulse cleaning not energized	Use a voltmeter to check the solenoid valves in the control panel. Check pneumatic lines for kinks or obstructions.
	Dust storage area overfilled or plugged	Clean out dust storage area. See Dust Disposal.
	Pulse valves leaking compressed air	Lock out all electrical power to the unit and bleed the compressed air supply. Check for debris, valve wear, pneumatic tubing fault, or diaphragm failure by removing the diaphragm cover on the pulse valves. Check for solenoid leaks or damage. If pulse valves or solenoid valves and tubing are damaged, replace.
	Solid-State timer failure	Using a voltmeter, check supply voltage to the timer board. Check and replace the fuse on the timer board if necessary. If the fuse is good and input power is present but output voltage to the solenoid is not, replace the timer board. See Solid-State Timer Installation.
	Solid-State timer out of adjustment	See Solid-State Timer and Solid-State Timer Wiring Diagram.

The Donaldson Torit Warranty

Donaldson warrants to the original purchaser that the major structural components of the goods will be free from defects in materials and workmanship for ten (10) years from the date of shipment, if properly installed, maintained and operated under normal conditions. Donaldson warrants all other Donaldson built components and accessories including Donaldson Airlocks, TBI Fans, TRB Fans, Fume Collector products, Donaldson built electrical control components and Donaldson built Afterfilter housings for twelve (12) months from date of shipment. Donaldson warrants Donaldson built filter elements to be free from defects in materials and workmanship for eighteen (18) months from date of shipment. Donaldson does not warrant against damages due to corrosion, abrasion, normal wear and tear, product modification, or product misapplication. Donaldson also makes no warranty whatsoever as to any goods manufactured or supplied by others including electric motors, fans and control components. After Donaldson has been given adequate opportunity to remedy any defects in material or workmanship, Donaldson retains the sole option to accept return of the goods, with freight paid by the purchaser, and to refund the purchase price for the goods after confirming the goods are returned undamaged and in usable condition. Such a refund will be in the full extent of Donaldson's liability. Donaldson shall not be liable for any other costs, expenses or damages whether direct, indirect, special, incidental, consequential or otherwise. The terms of this warranty may be modified only by a special warranty document signed by a Director, General Manager or Vice President of Donaldson. Failure to use genuine Donaldson replacement parts may void this warranty. THERE EXIST NO OTHER REPRESENTATIONS, WARRANTIES OR GUARANTEES EXCEPT AS STATED IN THIS PARAGRAPH AND ALL OTHER WARRANTIES INCLUDING MERCHANTABILITY AND FITNESS FOR A PARTICULAR PURPOSE, WHETHER EXPRESS OR IMPLIED ARE HEREBY EXPRESSLY EXCLUDED AND DISCLAIMED.



Donaldson
FILTRATION SOLUTIONS

Parts and Service

For genuine Donaldson replacement filters and parts, call the Parts Express Line. For faster service, have unit's model and serial number, quantity, part number, and description available.

Donaldson Company, Inc.
Industrial Air Filtration
PO Box 1299
Minneapolis, MN 55440-1299
U.S.A.

800-365-1331 USA
800-343-3639 within Mexico

donaldsontorit@donaldson.com
donaldsontorit.com

Donaldson Company, Inc. is the leading designer and manufacturer of dust, mist, and fume collection equipment used to control industrial-air pollutants. Our equipment is designed to help reduce occupational hazards, lengthen machine life, reduce in-plant maintenance requirements, and improve product quality.

© 2002 Donaldson Company, Inc.
Printed in USA

IOM 7539401 (ENG), Revision 7
August 2011