

## Oilfreepac 2000 Standard Oilfreepac 2000 Superplus Midi (Type 0020-60 to 0060-60)

Complete purification package including adsorption dryer, activated carbon adsorber, pre-, after filter and condensate drain.

The Oilfreepac 2000 purification packages are purification units based on adsorption dryers Ultrapac 2000 to supply clean, dry and oilfree compressed air. Compressed air is led through the inlet of the unit (J) and across the prefilter (2). At this stage, the air is cleaned from particles and condensate.

The condensate is removed via a membrane condensate drain (5). Via the lower shuttle valve (8) the air is led into desiccant cartridges (1) in which the air is dried down to a pressure dew point of  $-40^{\circ}\text{F}$  (equivalent to a remaining water content of 110 ppm). In the following activated carbon purification stage (9) oil vapours, hydrocarbons, taste and odours are adsorbed to a level far below 0.003 ppm.

The final particle filter (3) removes all particles which might be carried over from the adsorption stages. While one vessel with desiccant cartridges is in the drying phase (adsorption), the other cartridge is being dried again (regeneration). A partial stream of dried air is expanded to atmospheric pressure via an orifice (6) and led across the desiccant cartridge for regeneration and via a solenoid valve and a silencer system to atmosphere.



Oilfreepac 2000 Standard

Oilfreepac 2000	Volume flow in cfm*	Reg. air flow average cfm	Volume flow out (min.) cfm	Pressure loss initial psi
0020-60	20	3.5	15.8	1.4
0030-60	30	5.0	23.7	1.7
0040-60	40	6.5	31.6	2.2
0050-60	50	8.0	39.4	4.0
0060-60	60	10.0	47.3	6.5

\* Related to 14.7 psi (abs) and 68 °F at intake of compressor and 100 psig and 95 °F inlet temperature

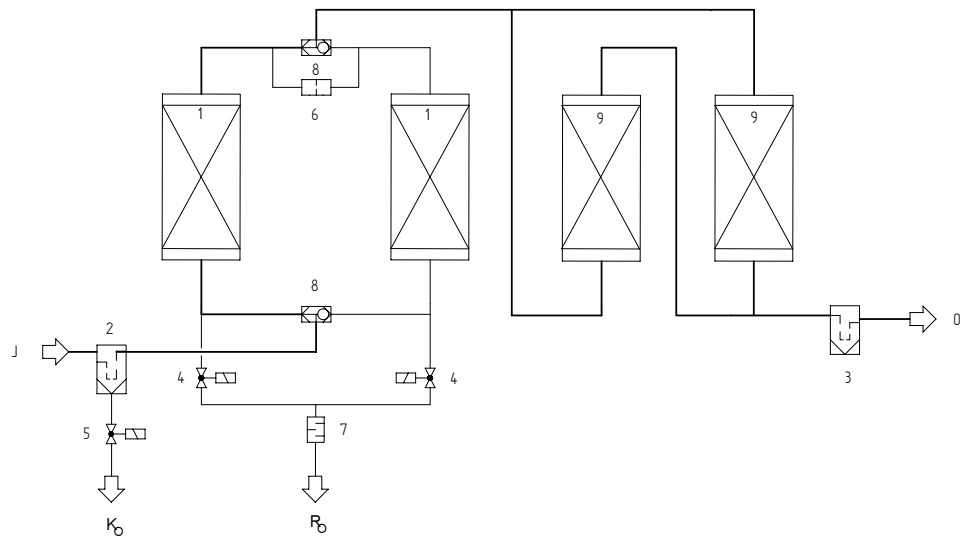

## Oilfreepac 2000 Standard Midi / Superplus Midi

Features Oilfreepac 2000:	Benefits:
Purification package including adsorption dryer, activated carbon adsorber, pre-, afterfilter and automatic condensate drain	Turnkey system, no additional installation costs; all components from one hand, therefore perfect technical match
Compressed air quality better than on any „oilfree“ installation	Use is highly sensitive production possible (food-, beverage-, electronic industry etc.)
Adsorbent in cartridges	Easy storage, transport and installation; optimum fixation of desiccant; no risk of fluidizing of desiccant.
Compact, space saving design	Installation in smallest spaces, possible also as retrofit
Component exchange display	High operating safety, due to calculation of optimum exchange point for filter elements and desiccant cartridges.
Unique Multifunction Block	All moving parts and all electronic components integrated in a function block, therefore easy and efficient maintenance

Features Oilfreepac 2000 Superplus:	Benefits:
Intermittent operation standard	Link between dryer and compressor possible on central applications, therefore saving of regeneration air
Load dependent control	Adjustment of adsorption cycles to the actual inlet water load, therefore saving of regeneration air and reduction of operating cost
Self-Diagnosis-System	Sensor-controlled monitoring of regeneration air flow, therefore without-gap-monitoring of dryer functions and of system pressure.
Text Display	Display of all operating status, of fault indication and maintenance intervals in clear text messages
Info-Channel	Serial interface for transmission of alarm- and maintenance messages
Economizer-Function	Online calculation of optimum exchange point of filter elements by continuous evaluation of energy cost versus cost of replacement filter element

Sizing:												
f	60 psig	70 psig	80 psig	90 psig	100 psig	110 psig	120 psig	150 psig	175 psig	200 psig	225 psig	
80°F	0.71	0.80	0.90	0.99	1.09	1.18	1.28	1.50	1.50	1.50	1.50	
90°F	0.71	0.80	0.90	0.99	1.09	1.18	1.28	1.50	1.50	1.50	1.50	
95°F	0.56	0.63	0.71	0.78	1.00	1.00	1.00	1.23	1.42	1.50	1.50	
110°F	0.42	0.48	0.53	0.59	0.64	0.70	0.76	0.93	1.07	1.21	1.35	
120°F	0.32	0.37	0.41	0.45	0.50	0.54	0.58	0.71	0.82	0.93	1.04	
130°F	0.25	0.29	0.32	0.36	0.39	0.42	0.46	0.56	0.65	0.73	0.82	

Example:  $\dot{V}_{nom} = 30 \text{ cfm}$ , Inlet temperature = 90°F, Operating pressure = 150 psig

$$\dot{V}_{corr} = \frac{\dot{V}_{nom}}{f}$$

$$\dot{V}_{corr} = \frac{30 \text{ cfm}}{1.50} = 20 \text{ cfm.}$$

Calculated dryer size: Oilfreepac 2000, type 0020-60

Product description:
<b>Oilfreepac 2000 Standard and Superplus:</b> Complete purification package including adsorption dryer, activated carbon adsorber, pre-, afterfilter and automatic condensate drain

Medium:
Compressed air

Operation pressure:
min. 60 psig, max. 225 psig

Medium temperature:
min. 40 °F, max. 122°F

Ambient temperature:
min. 39 °F, max. 122°F

Compressed air consumption:
17% of the rated flow, in average

Power supply:
230 V/ 50 -60 Hz AC; 110 V/ 50 -60 Hz AC 24 V DC; 24 V AC on request

Power consumption:
approx. 4 W

Noise level:
80 dB (A)

Air quality related to standard inlet conditions:	
Particles	< 0.01 ppm
Residual oil content	< 0.01 ppm
Oil vapour and hydrocarbons	< 0.003 ppm
Water vapour	PDP - 40°F (= 0.11 ppm)
Taste and odours	taste and odour free

**Oilfreepac 2000 Standard Midi**  
**Oilfreepac 2000 Superplus Midi**

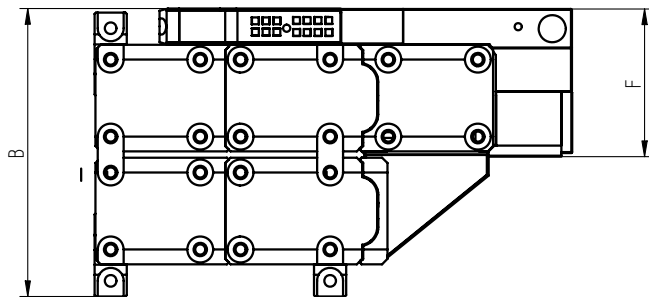
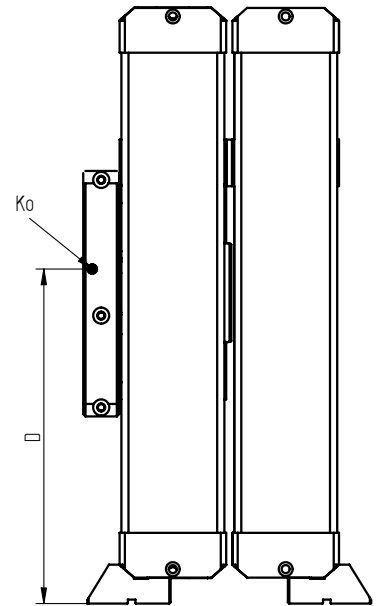
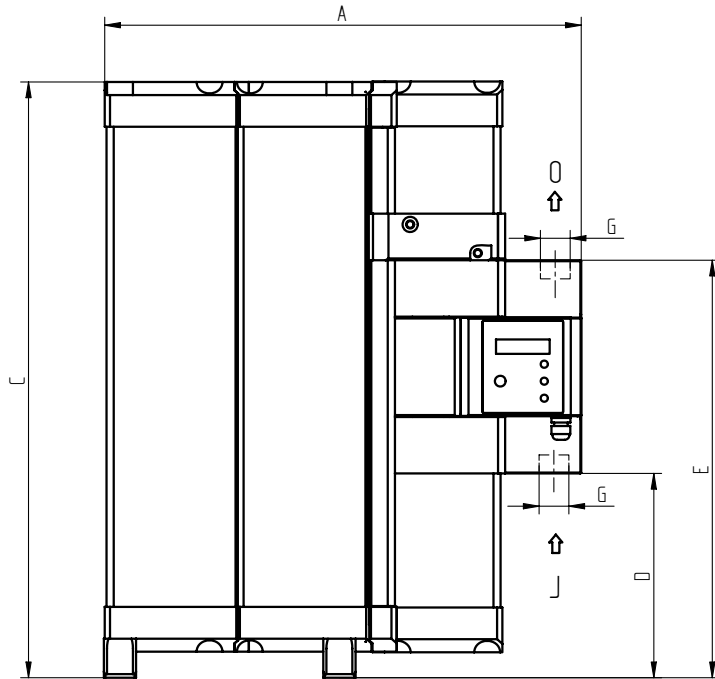

Oilfreepac 2000 - Midi							
Type	G "	A inch	B inch	C inch	D inch	E inch	F inch
0020-60	1	20.9	12.7	26.2	9.1	18.3	6.5
0030-60	1	20.9	12.7	36.2	14.0	23.4	6.5
0040-60	1	20.9	12.7	46.1	19.1	28.4	6.5
0050-60	1	20.9	12.7	55.9	23.8	33.3	6.5
0060-60	1	20.9	12.7	65.7	28.7	38.2	6.5