

FEATURES

Filter assembly W621 is manufactured to meet the HF3 automotive standard. Working pressure up to 6000 psi combined with a choice of 3 bowl lengths offer a wide range of flows and dirt holding capabilities. This T-type head design offers an option to the W620 L-type port option. Our standard bowl drain plug helps relieve system pressure during filter change outs. Western Filter's proprietary BetaPore™ 5 layer media is offered in a variety of Pak designs. Five different media grades are offered down to 4.0µ(c). WF elements core collapse options range from 150 to 3000 PSI. The differential pressure indicator line is designed to work with the wide assortment of bypass valves. Thermal lockout and surge control are two key features incorporated in many of the valves.

Western Filter elements are compatible with petroleum oils, water glycol, oil/water, HWCF and synthetic fluids.

Technical Data:

Maximum Working Pressure	6000 psi (414 bar)
Fatigue Pressure Rating	4000 psi max (276 bar)
Typical Burst Pressure	15000 psi max (1034 bar)
Temperature Range	Operating
Buna N	-45°F to + 225°F (-43°C to + 107°C)
Viton	-20°F to + 250°F (-29°C to + 121°C)
Head Material	Cast Iron
Bowl Material	Steel
Weight (without elements)	
Assembly length 1	34 lbs. (15,5 kg.)
Assembly length 2	38 lbs. (17,3 kg.)
Assembly length 4	42 lbs. (19,1 kg.)

W621

120 gpm (379 l/min)

Conforms to HF3 specifications

Replacement element available in C-Pak™ or H-Pak™ media

Accepts coreless elements with removable coretube

Wide range of indicator options

Three bowl length options for design flexibility

Available with reverse flow bypass option for hydrostatic applications



ACCESSORIES

Seal Kit -Buna N	P-236860-01
Seal Kit -E.P.R.	P-236860-02
Seal Kit -Viton	P-236860-03
Core Tube Assembly-Code Length-1	PW621R1BN
Core Tube Assembly-Code Length-2	PW621R2BN
Core Tube Assembly-Code Length-4	PW621R4BN

Housing and Filter Element

Flow versus Pressure Drop

150 SUS (32 cSt.) oil with specific gravity ≤ 0.9

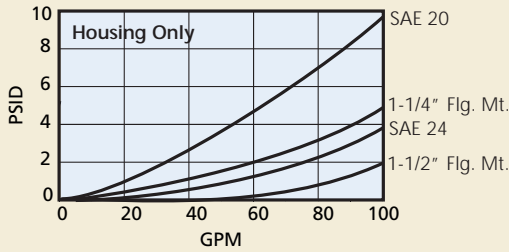

Viscosity Correction Formula

$$\Delta P \text{ Element} = \text{psid from catalog} \times \frac{\text{New Viscosity (SUS)}}{150} \times \frac{\text{New Specific Gravity}}{0.90}$$

$$\Delta P \text{ Housing} = \text{psid from catalog} \times \frac{\text{New Specific Gravity}}{0.90}$$

$$\Delta P \text{ Assembly} = \Delta P \text{ Element} + \Delta P \text{ Housing}$$

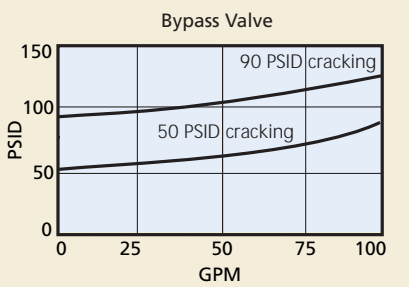
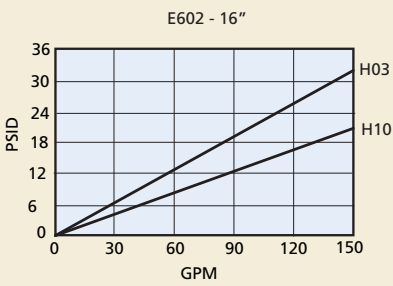
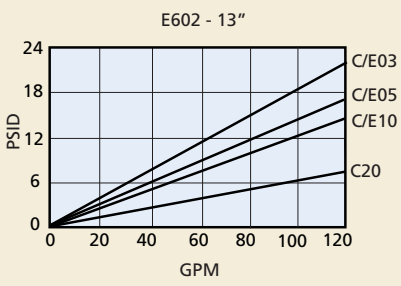
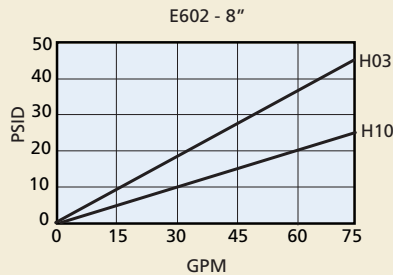
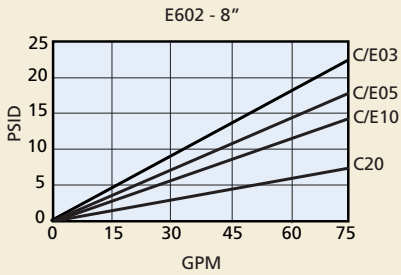
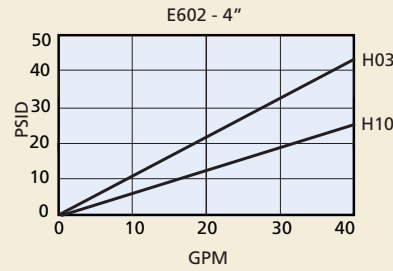
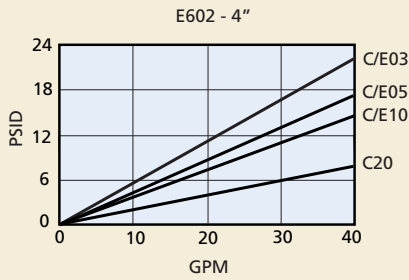

LOW PRESSURE SPIN-ON FILTERS
MEDIUM PRESSURE SPIN-ON FILTERS
IN-TANK FILTERS
LOW PRESSURE FILTERS
MEDIUM PRESSURE FILTERS
HIGH PRESSURE FILTERS

Filter Assembly	W621 TABLE 1	1 TABLE 2	C TABLE 3	4 TABLE 4	D B TABLE 5	B TABLE 6	2 TABLE 7	C TABLE 8	10 TABLE 9
Service Element	E602 TABLE 1	1 TABLE 2	B TABLE 6	2 TABLE 7	C TABLE 8	10 TABLE 9			

 Order model code **W6211Q4MNB4C10** for same day shipment.

Table 1

Filter Assembly / Service Element	
CODE	DESCRIPTION
W621	Assembly
E602	Element

Table 2

Element Collapse Options	
CODE	DESCRIPTION
1	150 psid for housing w/bypass valve
4	3000 psi for housing w/o bypass valve (H-Pak™ only)

Note: E-Pak™ elements rated at 100 psid collapse. If used in non-bypass housing, a differential pressure indicator (70 psid max.) should be used.

Table 3

Port Size Options	
CODE	PORT SIZE
C	1-5/8" - 12 UN (SAE 20)
D	1-7/8" - 12 UN (SAE 24)
E	1-1/2" 4 Bolt Flange Code 61
G	1-1/4" 4 Bolt Flange Code 61
Q	1-1/4" 4 Bolt Flange Code 62
R	1-1/2" SAE 4 Bolt Flange Code 62

Table 4

Bypass Setting Options	
CODE	BYPASS SETTING
1	Non-bypass
4	50 psid
6	90 psid
8	Non-bypass w/reverse flow valve
9	50 psid w/reverse flow valve

Note: Use option 1 only with 3000 psid collapse filter element.

Table 5 (Primary)

Indicator Style and Setting	
CODE	ΔP INDICATOR STYLE & SETTING
A	Visual indicator 70 psid w/TL and surge
B	Electrical/visual 70 psid w/TL and surge
D	Electrical/visual 35 psid
E	Electrical/visual 100 psid
G	Electrical/visual 35 psid w/TL
I	Visual indicator 70 psid
J	ΔP indicator plug
L	Visual indicator 35 psid
M	Visual indicator 35 psid w/ TL and surge
N	Electrical/visual 35 psid w/12" 3-wire flying lead
O	Visual indicator 100 psid
P	Visual indicator 100 psid w/ TL and surge
R	Electrical switch 35 psid
S	Electrical/visual 100 psid w/12" 3-wire flying lead
T	Electrical switch 100 psid
U	Electrical switch 70 psid
V	Electrical/visual 70 psid w/TL
W	Electrical/visual 100 psid w/TL
Y	Electrical/visual 35 psid w/TL and surge
Z	Electrical/visual 100 psid w/TL and surge

TL (thermal lockout)

Table 5 (Secondary)

Receptacle Options	
CODE	ELECTRICAL STYLE
B	Brad Harrison (5-pin)
H	Hirschmann (4-pin)
N	None, for visual ΔP

Table 6

Seal Options	
CODE	MATERIAL
B	Buna N
E	E.P.R.
V	Viton

Table 7

Assembly & Element Length	
CODE (LGTH)	ELEMENT LENGTH
1 (8.04")	4.0"
2 (11.67")*	8.0"*
4 (16.39")	13.0"

*HF3

Table 8

Element Code	
CODE	DESCRIPTION
C	(Glass) 01, 03, 05, 10, 20
E	(Coreless) 01, 03, 05, 10
H	(Glass) 03, 10
W	(Water Removal) 10

Table 9

Media Rating	
CODE	TARGET FLUID CLEANLINESS LEVEL
01	Flushing only
03	16/14/12 or better
05	18/16/14 or better
10	20/18/15 or better
20	22/19/16 or better

Note: Information concerning fluid cleanliness codes is on page 6, the Media Grade Selection Guide.

Metric Porting Available

Change W621 to G621

Porting code C becomes G1-1/4" ISO 228 BSPP

Porting code D becomes G1-1/2" ISO 228 BSPP

Porting code E becomes 1-1/2" SAE 4 bolt flange with M12 mounting threads

Porting code G becomes 1-1/4" SAE 4 bolt flange with M10 mounting threads

Porting code Q becomes 1-1/4" SAE 4 bolt flange with M14 mounting threads

Porting code R becomes 1-1/2" SAE 4 bolt flange with M16 mounting threads

Indicator Switch Schematic Wiring Diagram

Aluminum Electrical Housings

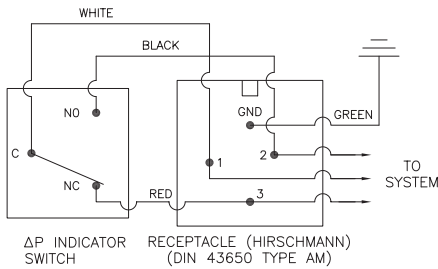
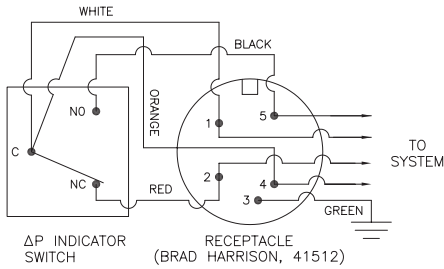

Note: The female plug (connector) is to be furnished by customer.

Plastic Electrical Housings

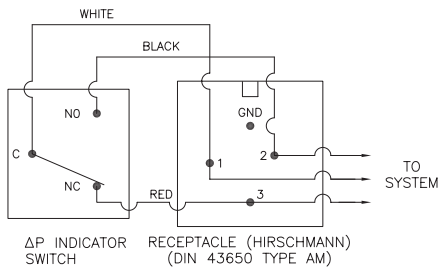
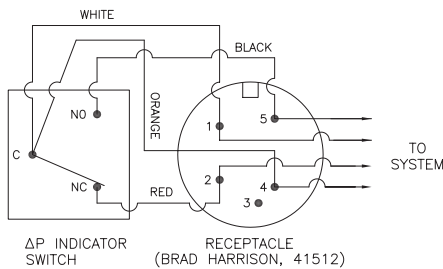

Note: The female plug (connector) is to be furnished by customer.

Dimensions:
millimeters/(inches)

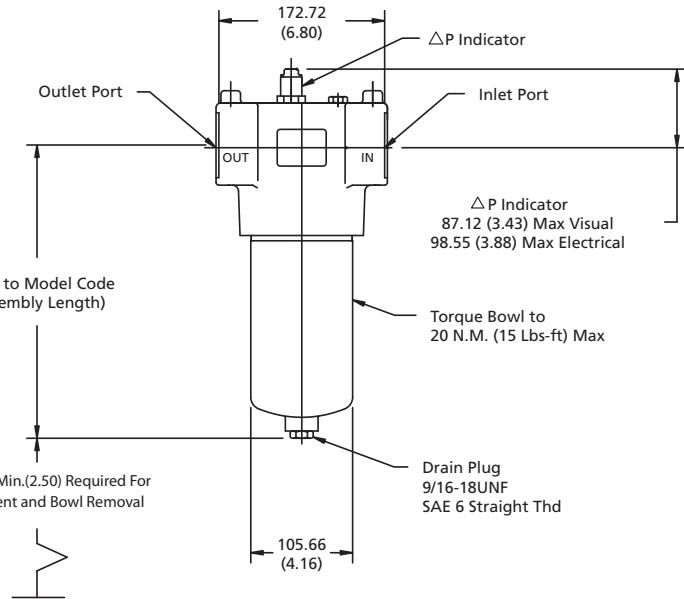
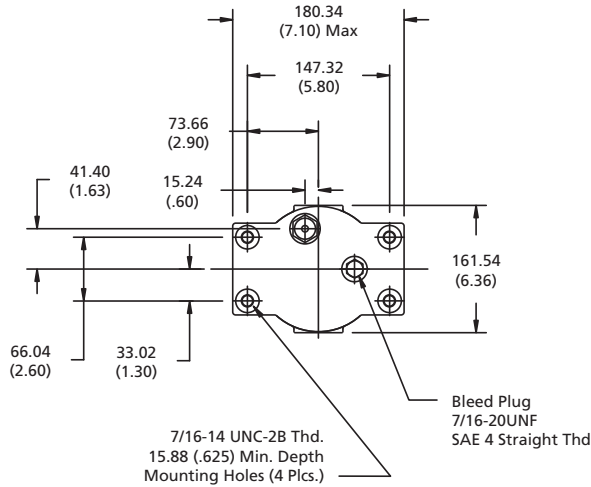

Differential Indicators: Indicators are designed to actuate at approximately 80% of bypass valve cracking pressure. It is recommended that an indicator with a bypass setting of 100 psid is used with a non-bypass housing.

Surge Control: This optional feature is used to dampen pressure surges or spikes to avoid premature actuation of the indicator. Surge control delays the indicator response.

Thermal Lockout: The Thermal Lockout prevents premature signaling of a bypass condition created by viscous fluid during cold start-ups. Normal indicator actuation capability is resumed once the operating temperature of the fluid reaches approximately 80 Deg. F.