

# Dalamatic Insertable Dust Collectors

## Series DLM V

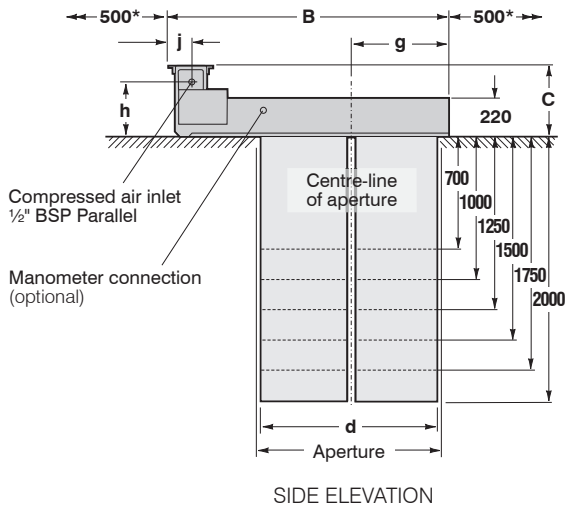

Seating level

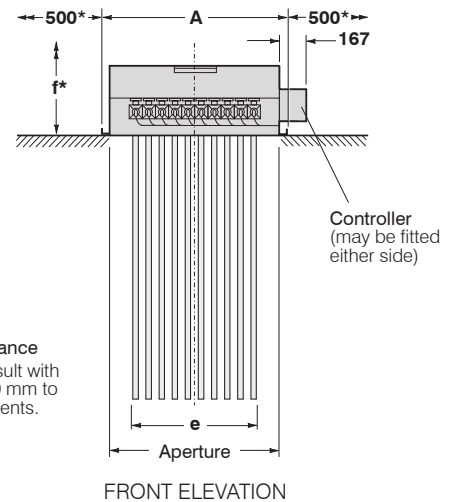

\* Nominal clearances for maintenance  
Where space is restricted please consult with Donaldson. Clearance of at least 150 mm to be left on all sides of the filter elements.

### DALAMATIC BASIC TYPE INSERTABLE DUST COLLECTOR

Model DLM V40/20B illustrated, broken lines representing models DLM V14/7B, DLM V20/10B, DLM V25/12B, DLM V30/15B and DLM V35/17B. Suitable for inside locations.

DLM type	Filtration area	Number of elements	A	B	C	DIMENSIONS in mm			g	h	j	Net weight (approx.)
						d	e	f*				
V3/7B	3 m <sup>2</sup>	4	524	1015	375	480	294	850	310	295	115	80 kg ‡
V4/7B	4 m <sup>2</sup>	6	700	1015	375	480	470	850	310	295	115	105 kg ‡
V5/12B	5 m <sup>2</sup>	4	524	1015	375	480	294	1400	310	295	115	90 kg ‡
V6/10B	6 m <sup>2</sup>	6	700	1015	375	480	470	1150	310	295	115	114 kg ‡
V7/7B	7 m <sup>2</sup>	10	1100	1015	375	480	820	850	310	295	115	160 kg ‡
V7.5/12B	7.5 m <sup>2</sup>	6	700	1015	375	480	470	1400	310	295	115	119 kg ‡
V8/7B	8 m <sup>2</sup>	12	700	1625	400	1005	470	850	575	310	130	170 kg ‡
V9/15B	9 m <sup>2</sup>	6	700	1015	375	480	470	1650	310	295	115	124 kg ‡
V10/10B	10 m <sup>2</sup>	10	1100	1015	375	480	820	1150	310	295	115	175 kg ‡
V12/10B	12 m <sup>2</sup>	12	700	1625	400	1005	470	1150	575	310	130	188 kg ‡
V13/12B	13 m <sup>2</sup>	10	1100	1015	375	480	820	1400	310	295	115	184 kg ‡
V14/7B	14 m <sup>2</sup>	20	1100	1625	400	1005	820	850	575	310	130	275 kg ‡
V15/12B	15 m <sup>2</sup>	12	700	1625	400	1005	470	1400	575	310	130	198 kg ‡
V15/15B	15 m <sup>2</sup>	10	1100	1015	375	480	820	1650	310	295	115	192 kg ‡
V18/15B	18 m <sup>2</sup>	12	700	1625	400	1005	470	1650	575	310	130	208 kg ‡
V20/10B	20 m <sup>2</sup>	20	1100	1625	400	1005	820	1150	575	310	130	305 kg ‡
V21/7B	21 m <sup>2</sup>	30	1100	2225	400	1605	820	850	875	310	130	360 kg ‡
V25/12B	25 m <sup>2</sup>	20	1100	1625	400	1005	820	1400	575	310	130	322 kg ‡
V30/10B	30 m <sup>2</sup>	30	1100	2225	400	1605	820	1150	875	310	130	405 kg ‡
V30/15B	30 m <sup>2</sup>	20	1100	1625	400	1005	820	1650	575	310	130	340 kg ‡
V35/17B	35 m <sup>2</sup>	20	1100	1625	400	1005	820	1900	575	310	130	362 kg ‡
V38/12B	38 m <sup>2</sup>	30	1100	2225	400	1605	820	1400	875	310	130	430 kg ‡
V40/20B	40 m <sup>2</sup>	20	1100	1625	400	1005	820	2150	575	310	130	379 kg ‡
V45/15B	45 m <sup>2</sup>	30	1100	2225	400	1605	820	1650	875	310	130	455 kg ‡
V50/12B	50 m <sup>2</sup>	40	1100	2747	400	2130	820	1400	1137	310	130	564 kg ‡
V52/17B	52 m <sup>2</sup>	30	1100	2225	400	1605	820	1900	875	310	130	485 kg ‡
V60/15B	60 m <sup>2</sup>	40	1100	2747	400	2130	820	1650	1137	310	130	600 kg ‡
V60/20B	60 m <sup>2</sup>	30	1100	2225	400	1605	820	2150	875	310	130	510 kg ‡
V70/17B	70 m <sup>2</sup>	40	1100	2747	400	2130	820	1900	1137	310	130	643 kg ‡
V80/20B	80 m <sup>2</sup>	40	1100	2747	400	2130	820	2150	1137	310	130	677 kg ‡

‡ Indicates heaviest configuration.

**Dalamic Insertable Dust Collectors – Series DLM V**

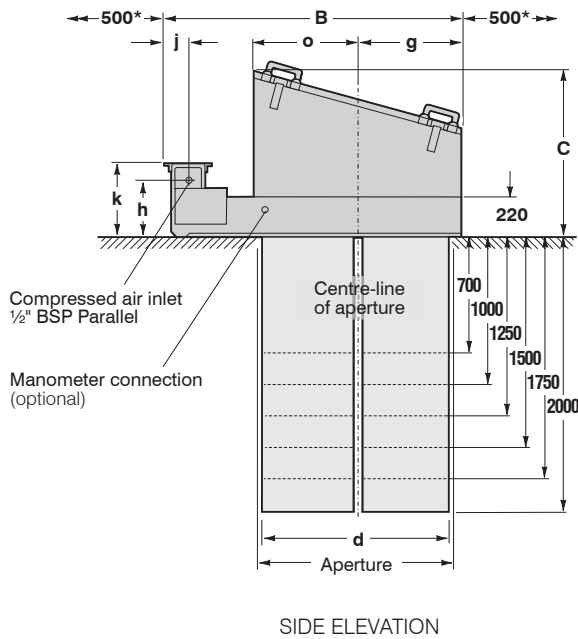

Note: The DLM V50/12H, V60/15H, V70/17H and V80/20H are each supplied with a flat-topped header and hinged access doors.

Seating level

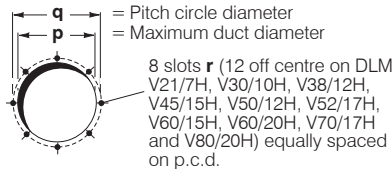

**CUTOUT DETAILS**

\* Nominal clearances for maintenance  
Where space is restricted please consult with Donaldson. Clearance of at least 150 mm to be left on all sides of the filter elements.

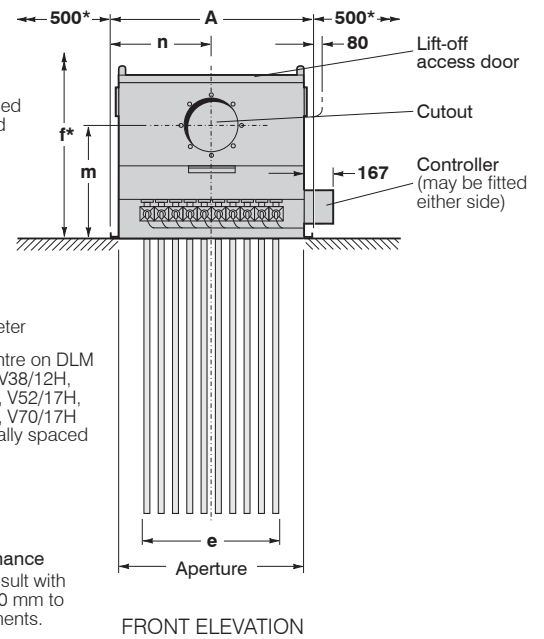

**DALAMATIC INSERTABLE DUST COLLECTOR WITH EXIT HEADER**

Model DLM V40/20H illustrated, broken lines representing models DLM V14/7H, DLM V20/10H, DLM V25/12H, DLM V30/15H and DLM V35/17H. Suitable for inside and outside locations.

DLM type	Filtration area	Number of elements	A	B	C	d	e	f*	g	h	j	k	m	n	o	p	q	r	Net weight (approx.)
V3/7H	3 m <sup>2</sup>	4	524	1015	935	480	294	1250	310	295	115	375	552	227	295	220	245	8 x 12	115 kg ‡
V4/7H	4 m <sup>2</sup>	6	700	1015	935	480	470	1250	310	295	115	375	552	350	295	220	245	8 x 12	145 kg ‡
V5/12H	5 m <sup>2</sup>	4	524	1015	935	480	294	1800	310	295	115	375	552	227	295	220	245	8 x 12	145 kg ‡
V6/10H	6 m <sup>2</sup>	6	700	1015	935	480	470	1550	310	295	115	375	552	350	295	220	245	8 x 12	154 kg ‡
V7/7H	7 m <sup>2</sup>	10	1100	1015	935	480	820	1250	310	295	115	375	562	550	295	285	310	10 x 20	215 kg ‡
V7.5/12H	7.5 m <sup>2</sup>	6	700	1015	935	480	470	1800	310	295	115	375	552	350	295	220	245	8 x 12	159 kg ‡
V8/7H	8 m <sup>2</sup>	12	700	1625	935	1005	470	1250	575	310	130	400	592	290	555	285	310	10 x 20	235 kg ‡
V9/15H	9 m <sup>2</sup>	6	700	1015	935	480	470	2050	310	295	115	375	562	290	295	285	310	10 x 20	164 kg ‡
V10/10H	10 m <sup>2</sup>	10	1100	1015	935	480	820	1550	310	295	115	375	562	550	295	285	310	10 x 20	230 kg ‡
V12/10H	12 m <sup>2</sup>	12	700	1625	935	1005	470	1550	575	310	130	400	610	290	555	285	310	10 x 20	253 kg ‡
V13/12H	13 m <sup>2</sup>	10	1100	1015	935	480	820	1800	310	295	115	375	562	550	295	285	310	10 x 20	239 kg ‡
V14/7H	14 m <sup>2</sup>	20	1100	1625	935	1005	820	1250	575	310	130	400	610	550	555	285	310	10 x 20	360 kg ‡
V15/12H	15 m <sup>2</sup>	12	700	1625	935	1005	470	1800	575	310	130	400	610	290	555	285	310	10 x 20	263 kg ‡
V15/15H	15 m <sup>2</sup>	10	1100	1015	935	480	820	2050	310	295	115	375	580	550	295	285	310	10 x 20	247 kg ‡
V18/15H	18 m <sup>2</sup>	12	700	1625	935	1005	470	2050	575	310	130	400	610	290	555	285	310	10 x 20	273 kg ‡
V20/10H	20 m <sup>2</sup>	20	1100	1625	935	1005	820	1550	575	310	130	400	610	550	555	285	310	10 x 20	390 kg ‡
V21/7H	21 m <sup>2</sup>	30	1100	2225	1090	1605	820	1150	875	310	130	400	670	550	855	500	550	10 x 20	480 kg ‡
V25/12H	25 m <sup>2</sup>	20	1100	1625	935	1005	820	1800	575	310	130	400	610	550	555	285	310	10 x 20	407 kg ‡
V30/10H	30 m <sup>2</sup>	30	1100	2225	1090	1605	820	1450	875	310	130	400	670	550	855	500	550	10 x 20	525 kg ‡
V30/15H	30 m <sup>2</sup>	20	1100	1625	935	1005	820	2050	575	310	130	400	610	550	285	315	340	10 x 20	424 kg ‡
V35/17H	35 m <sup>2</sup>	20	1100	1625	935	1005	820	2300	575	310	130	400	610	550	555	315	340	10 x 20	432 kg ‡
V38/12H	38 m <sup>2</sup>	30	1100	2225	1090	1605	820	1700	875	310	130	400	670	550	855	500	550	∅12	550 kg ‡
V40/20H	40 m <sup>2</sup>	20	1100	1625	935	1005	820	2550	575	310	130	400	610	550	555	315	340	10 x 20	449 kg ‡
V45/15H	45 m <sup>2</sup>	30	1100	2225	1090	1605	820	1950	875	310	130	400	670	550	855	500	550	∅12	575 kg ‡
V50/12H	50 m <sup>2</sup>	40	1100	2747	1090	2130	820	1960	1137	310	130	400	670	550	1118	500	550	∅12	819 kg ‡
V52/17H	52 m <sup>2</sup>	30	1100	2225	1090	1605	820	2200	875	310	130	400	670	550	855	500	550	∅12	585 kg ‡
V60/15H	60 m <sup>2</sup>	40	1100	2747	1090	2130	820	2210	1137	310	130	400	670	550	1118	500	550	∅12	852 kg ‡
V60/20H	60 m <sup>2</sup>	30	1100	2225	1090	1605	820	2450	875	310	130	400	670	550	855	500	550	∅12	610 kg ‡
V70/17H	70 m <sup>2</sup>	40	1100	2747	1090	2130	820	2460	1137	310	130	400	670	550	1088	500	550	∅12	848 kg ‡
V80/20H	80 m <sup>2</sup>	40	1100	2747	1090	2130	820	2710	1137	310	130	400	670	550	1088	500	550	∅12	882 kg ‡

‡ Indicates heaviest configuration.

Dalamatic Insertable Dust Collectors – Series DLM V

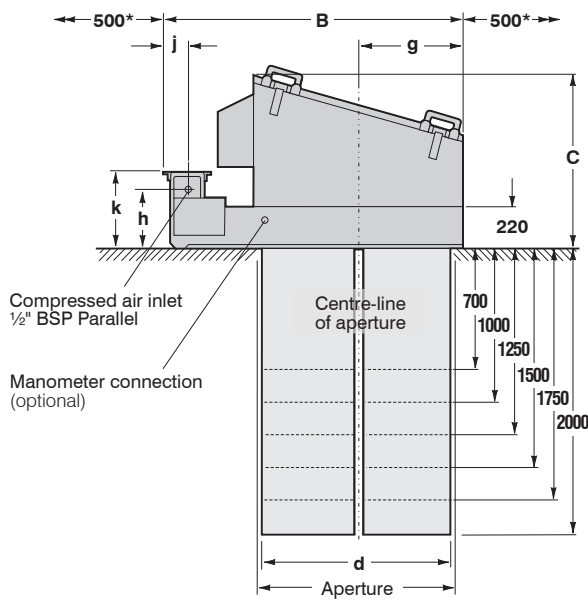

SIDE ELEVATION

Note: The DLM V50/12W, V60/15W, V70/17W and V80/20W are each supplied with a flat-topped header and hinged access doors.

Seating level

\* Nominal clearances for maintenance  
Where space is restricted please consult with Donaldson. Clearance of at least 150 mm to be left on all sides of the filter elements.

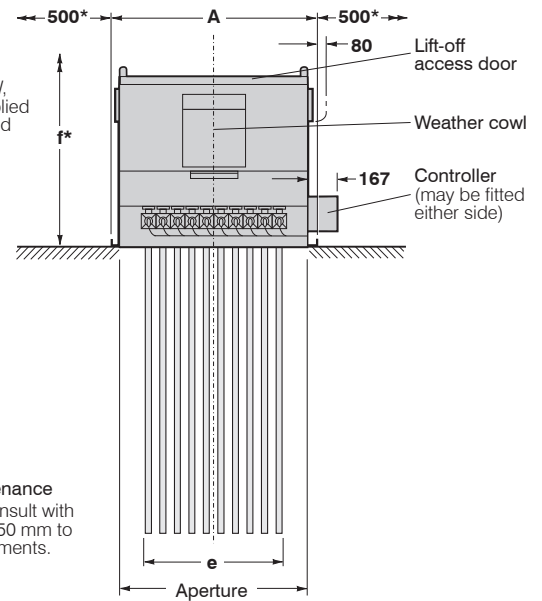

FRONT ELEVATION

**DALAMATIC INSERTABLE DUST COLLECTOR WITH WEATHER COWL**

Model DLM V40/20W illustrated, broken lines representing models DLM V14/7W, DLM V20/10W, DLM V25/12W, DLM V30/15W and DLM V35/17W. Suitable for inside and outside locations.

DLM type	Filtration area	Number of elements	DIMENSIONS in mm										Net weight (approx.)
			A	B	C	d	e	f*	g	h	j	k	
V3/7W	3 m <sup>2</sup>	4	524	1015	935	480	294	1250	310	295	115	375	118 kg ‡
V4/7W	4 m <sup>2</sup>	6	700	1015	935	480	470	1250	310	295	115	375	150 kg ‡
V5/12W	5 m <sup>2</sup>	4	524	1015	935	480	294	1800	310	295	115	375	128 kg ‡
V6/10W	6 m <sup>2</sup>	6	700	1015	935	480	470	1550	310	295	115	375	159 kg ‡
V7/7W	7 m <sup>2</sup>	10	1100	1015	935	480	820	1250	310	295	115	375	160 kg ‡
V7.5/12W	7.5 m <sup>2</sup>	6	700	1015	935	480	470	1800	310	295	115	375	164 kg ‡
V8/7W	8 m <sup>2</sup>	12	700	1625	935	1005	470	1250	575	310	130	400	240 kg ‡
V9/15W	9 m <sup>2</sup>	6	700	1015	935	480	470	2050	310	295	115	375	169 kg ‡
V10/10W	10 m <sup>2</sup>	10	1100	1015	935	480	820	1550	310	295	115	375	230 kg ‡
V12/10W	12 m <sup>2</sup>	12	700	1625	935	1005	470	1550	575	310	130	400	258 kg ‡
V13/12W	13 m <sup>2</sup>	10	1100	1015	935	480	820	1800	310	295	115	375	244 kg ‡
V14/7W	14 m <sup>2</sup>	20	1100	1625	935	1005	820	1250	575	310	130	400	365 kg ‡
V15/12W	15 m <sup>2</sup>	12	700	1625	935	1005	470	1800	575	310	130	400	268 kg ‡
V15/15W	15 m <sup>2</sup>	10	1100	1015	935	480	820	2050	310	295	115	375	252 kg ‡
V18/15W	18 m <sup>2</sup>	12	700	1625	935	1005	470	2050	575	310	130	400	278 kg ‡
V20/10W	20 m <sup>2</sup>	20	1100	1625	935	1005	820	1550	575	310	130	400	395 kg ‡
V21/7W	21 m <sup>2</sup>	30	1100	2225	1090	1605	820	1150	875	310	130	400	490 kg ‡
V25/12W	25 m <sup>2</sup>	20	1100	1625	935	1005	820	1800	575	310	130	400	412 kg ‡
V30/10W	30 m <sup>2</sup>	30	1100	2225	1090	1605	820	1450	875	310	130	400	535 kg ‡
V30/15W	30 m <sup>2</sup>	20	1100	1625	935	1005	820	2050	575	310	130	400	429 kg ‡
V35/17W	35 m <sup>2</sup>	30	1100	1625	935	1005	820	2300	575	310	130	400	437 kg ‡
V38/12W	38 m <sup>2</sup>	30	1100	2225	1090	1605	820	1700	875	310	130	400	560 kg ‡
V40/20W	40 m <sup>2</sup>	20	1100	1625	935	1005	820	2550	575	310	130	400	454 kg ‡
V45/15W	45 m <sup>2</sup>	30	1100	2225	1090	1605	820	1950	875	310	130	400	585 kg ‡
V50/12W	50 m <sup>2</sup>	40	1100	2747	1090	2130	820	1960	1137	310	130	400	829 kg ‡
V52/17W	52 m <sup>2</sup>	30	1100	2225	1090	1605	820	2200	875	310	130	400	595 kg ‡
V60/15W	60 m <sup>2</sup>	40	1100	2747	1090	2130	820	2210	1137	310	130	400	862 kg ‡
V60/20W	60 m <sup>2</sup>	30	1100	2225	1090	1605	820	2450	875	310	130	400	620 kg ‡
V70/17W	70 m <sup>2</sup>	40	1100	2747	1090	2130	820	2460	1137	310	130	400	858 kg ‡
V80/20W	80 m <sup>2</sup>	40	1100	2747	1090	2130	820	2710	1137	310	130	400	892 kg ‡

‡ Indicates heaviest configuration.

**Dalamic Insertable Dust Collectors – Series DLM V**

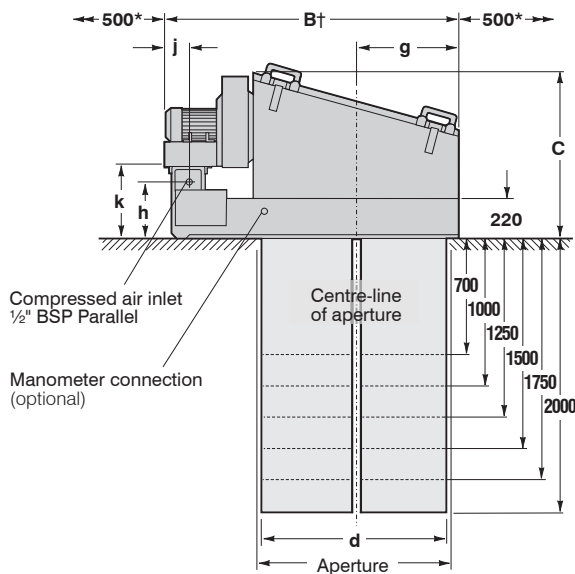

SIDE ELEVATION

Note: The DLM V50/12F, V60/15F, V70/17F and V80/20F are each supplied with a flat-topped header and hinged access doors.

Seating level

† This dimension is approximate and is dependent on make of motor.

\* Nominal clearances for maintenance  
Where space is restricted please consult with Donaldson. Clearance of at least 150 mm to be left on all sides of the filter elements.

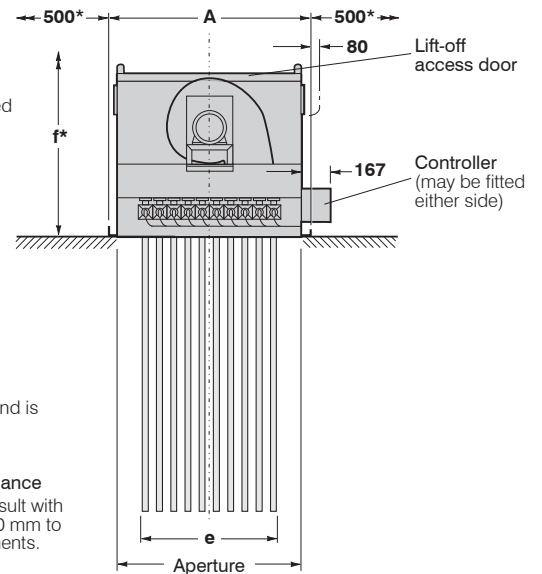

FRONT ELEVATION

**DALAMATIC INSERTABLE DUST COLLECTOR WITH INTEGRAL FAN**

Model DLM V40/20F illustrated, broken lines representing models DLM V14/7F, DLM V20/10F, DLM V25/12F, DLM V30/15F and DLM V35/17F. Suitable for inside and outside locations.

DLM type	Filtration area	Number of elements	DIMENSIONS in mm										Fan	Fan motor	Net weight (approx.)
			A	B†	C	d	e	f*	g	h	j	k			
V3/7F	3 m <sup>2</sup>	4	524	1095	935	480	294	1250	310	295	195	375	F1	0.75 kW	165 kg ‡
V4/7F	4 m <sup>2</sup>	6	700	1095	935	480	470	1250	310	295	195	375	F1	0.75 kW	195 kg ‡
													K3	1.50 kW	200 kg ‡
													K5	2.20 kW	215 kg ‡
V5/12F	5 m <sup>2</sup>	4	524	1095	935	480	294	1800	310	295	195	375	F1	0.75 kW	175 kg ‡
V6/10F	6 m <sup>2</sup>	6	700	1095	935	480	470	1550	310	295	195	375	F1	0.75 kW	204 kg ‡
													K3	1.50 kW	209 kg ‡
													K5	2.20 kW	224 kg ‡
V7/7F	7 m <sup>2</sup>	10	1100	1095	935	480	820	1250	310	295	195	375	F1	0.75 kW	265 kg ‡
													K3	1.50 kW	270 kg ‡
													K5	2.20 kW	285 kg ‡
V7.5/12F	7.5 m <sup>2</sup>	6	700	1095	935	480	470	1800	310	295	195	375	F1	0.75 kW	209 kg ‡
													K3	1.50 kW	214 kg ‡
													K5	2.20 kW	229 kg ‡
V8/7F	8 m <sup>2</sup>	12	700	1625	935	1005	470	1250	575	310	130	400	F1	0.75 kW	285 kg ‡
													K3	1.50 kW	290 kg ‡
V9/15F	9 m <sup>2</sup>	6	700	1095	935	480	470	2050	310	295	195	375	F1	0.75 kW	214 kg ‡
													K3	1.50 kW	219 kg ‡
													K5	2.20 kW	234 kg ‡
V10/10F	10 m <sup>2</sup>	10	1100	1095	935	480	820	1550	310	295	195	375	F1	0.75 kW	280 kg ‡
													K3	1.50 kW	285 kg ‡
													K5	2.20 kW	300 kg ‡
V12/10F	12 m <sup>2</sup>	12	700	1625	935	1005	470	1550	575	310	130	400	F1	0.75 kW	303 kg ‡
													K3	1.50 kW	308 kg ‡
													K5	2.20 kW	323 kg ‡
													K7	3.00 kW	348 kg ‡
V13/12F	13 m <sup>2</sup>	10	1100	1095	935	480	820	1800	310	295	195	375	F1	0.75 kW	289 kg ‡
													K3	1.50 kW	294 kg ‡
													K5	2.20 kW	309 kg ‡
V14/7F	14 m <sup>2</sup>	20	1100	1625	935	1005	820	1250	575	310	130	400	K3	1.50 kW	415 kg ‡
													K5	2.20 kW	430 kg ‡
													K7	3.00 kW	455 kg ‡
V15/12F	15 m <sup>2</sup>	12	700	1625	935	1005	470	1800	575	310	130	400	K3	1.50 kW	318 kg ‡
													K5	2.20 kW	333 kg ‡
													K7	3.00 kW	358 kg ‡

‡ Indicates heaviest configuration.

Dalamic Insertable Dust Collectors – Series DLM V

DLM type	Filtration area	Number of elements	DIMENSIONS in mm										Fan	Fan motor	Net weight (approx.)
			A	B†	C	d	e	f*	g	h	j	k			
V15/15F	15 m <sup>2</sup>	10	1100	1015	935	480	820	2050	310	295	115	375	F1 K3 K5	0.75 kW 1.50 kW 2.20 kW	297 kg ‡ 302 kg ‡ 317 kg ‡
V18/15F	18 m <sup>2</sup>	12	700	1625	935	1005	470	2050	575	310	130 130 180	400	K3 K5 K7	1.50 kW 2.20 kW 3.00 kW	328 kg ‡ 343 kg ‡ 378 kg ‡
V20/10F	20 m <sup>2</sup>	20	1100	1625	935	1005	820	1550	575	310	130 130 180 235	400	K3 K5 K7 K10	1.50 kW 2.20 kW 3.00 kW 5.50 kW	445 kg ‡ 460 kg ‡ 495 kg ‡ 525 kg ‡
V21/7F	21 m <sup>2</sup>	30	1100	2225	1090	1605	820	1150	875	310	130 130 180	400	K3 K5 K7	1.50 kW 2.20 kW 3.00 kW	535 kg ‡ 550 kg ‡ 585 kg ‡
V25/12F	25 m <sup>2</sup>	20	1100	1625	935 935 935 950 975	1005	820	1800	575	310	130 130 180 235 270	400	K3 K5 K7 K10 K11	1.50 kW 2.20 kW 3.00 kW 5.50 kW 7.50 kW	462 kg ‡ 477 kg ‡ 492 kg ‡ 582 kg ‡ 642 kg ‡
V30/10F	30 m <sup>2</sup>	30	1100	2225 2225 2330 2365	1090	1605	820	1450	875	310	130 180 235 270	400	K5 K7 K10 K11	2.20 kW 3.00 kW 5.50 kW 7.50 kW	595 kg ‡ 630 kg ‡ 708 kg ‡ 768 kg ‡
V30/15F	30 m <sup>2</sup>	20	1100	1625 1625 1625 1730 1765	935 935 935 950 975	1005	820	2050	575	310	130 130 180 235 270	400	K3 K5 K7 K10 K11	1.50 kW 2.20 kW 3.00 kW 5.50 kW 7.50 kW	479 kg ‡ 494 kg ‡ 530 kg ‡ 599 kg ‡ 659 kg ‡
V35/17F	35 m <sup>2</sup>	20	1100	1625 1625 1625 1730 1765	935 935 935 950 975	1005	820	2300	575	310	130 130 180 235 270	400	K3 K5 K7 K10 K11	1.50 kW 2.20 kW 3.00 kW 5.50 kW 7.50 kW	487 kg ‡ 502 kg ‡ 537 kg ‡ 567 kg ‡ 627 kg ‡
V38/12F	38 m <sup>2</sup>	30	1100	2225 2225 2330 2365	1090	1605	820	1700	875	310	130 180 235 270	400	K5 K7 K10 K11	2.20 kW 3.00 kW 5.50 kW 7.50 kW	630 kg ‡ 655 kg ‡ 733 kg ‡ 773 kg ‡
V40/20F	40 m <sup>2</sup>	20	1100	1625 1625 1625 1730 1765	935 935 935 950 975	1005	820	2550	575	310	130 130 180 235 270	400	K3 K5 K7 K10 K11	1.50 kW 2.20 kW 3.00 kW 5.50 kW 7.50 kW	504 kg ‡ 519 kg ‡ 554 kg ‡ 584 kg ‡ 644 kg ‡
V45/15F	45 m <sup>2</sup>	30	1100	2225 2225 2330 2365	1090	1605	820	1950	875	310	130 180 235 270	400	K5 K7 K10 K11	2.20 kW 3.00 kW 5.50 kW 7.50 kW	655 kg ‡ 680 kg ‡ 758 kg ‡ 798 kg ‡
V50/12F	50 m <sup>2</sup>	40	1100	2890 2890 3130	1090 1090 1130	2130	820	1960	1137	310	270 270 370	400	K10 K11 K15	5.50 kW 7.50 kW 11.00 kW	984 kg ‡ 1044 kg ‡ 1102 kg ‡
V52/17F	52 m <sup>2</sup>	30	1100	2225 2225 2330 2365	1090	1605	820	2200	875	310	130 180 235 270	400	K5 K7 K10 K11	2.20 kW 3.00 kW 5.50 kW 7.50 kW	665 kg ‡ 690 kg ‡ 768 kg ‡ 808 kg ‡
V60/15F	60 m <sup>2</sup>	40	1100	2890 2890 3130	1090 1090 1130	2130	820	2210	1137	310	270 270 370	400	K10 K11 K15	5.50 kW 7.50 kW 11.00 kW	1017 kg ‡ 1077 kg ‡ 1135 kg ‡
V60/20F	60 m <sup>2</sup>	30	1100	2225 2225 2330 2365	1090	1605	820	2450	875	310	130 180 235 270	400	K5 K7 K10 K11	2.20 kW 3.00 kW 5.50 kW 7.50 kW	690 kg ‡ 715 kg ‡ 793 kg ‡ 833 kg ‡
V70/17F	70 m <sup>2</sup>	40	1100	2890 2890 3130	1090 1090 1130	2130	820	2460	1137	310	270 270 370	400	K10 K11 K15	5.50 kW 7.50 kW 11.00 kW	1013 kg ‡ 1073 kg ‡ 1131 kg ‡
V80/20F	80 m <sup>2</sup>	40	1100	2890 2890 3130	1090 1090 1130	2130	820	2710	1137	310	270 270 370	400	K10 K11 K15	5.50 kW 7.50 kW 11.00 kW	1047 kg ‡ 1107 kg ‡ 1165 kg ‡

‡ Indicates heaviest configuration.

**Dalamic Insertable Dust Collectors – Series DLM V**

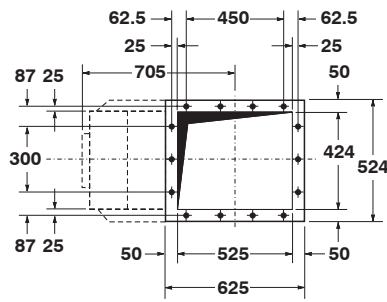

**DLM V3/7 AND V5/12**

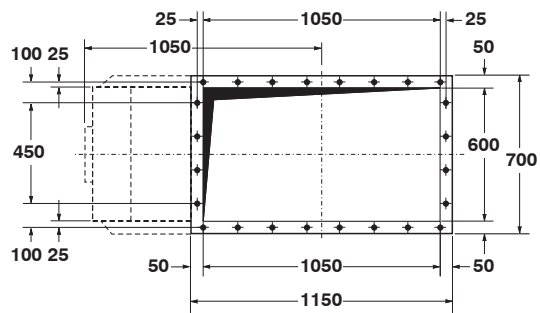

**DLM V8/7, V12/10, V15/12 AND V18/15**

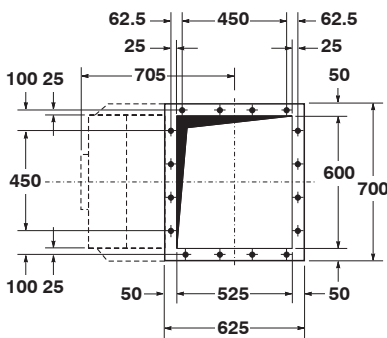

**DLM V4/7, V6/10, V7.5/12 AND V9/15**

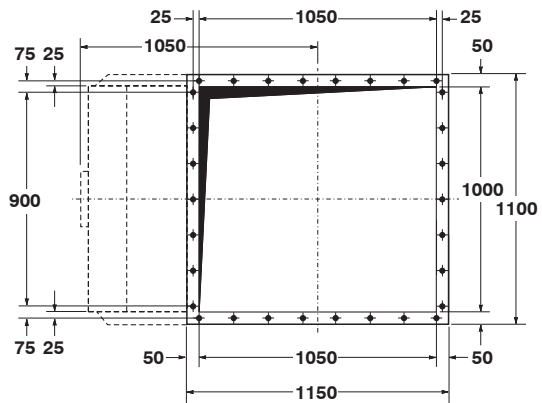

**DLM V14/7, V20/10, V25/12, V30/15, V35/17 AND V40/20**

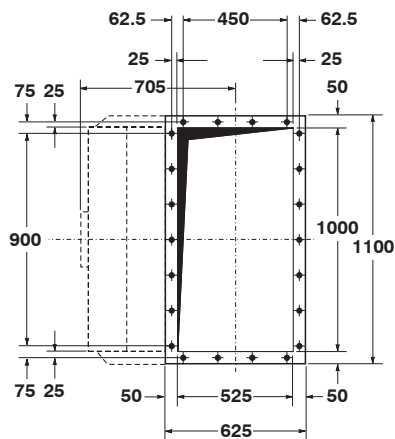

**DLM V7/7, V10/10, V13/12 AND V15/15**

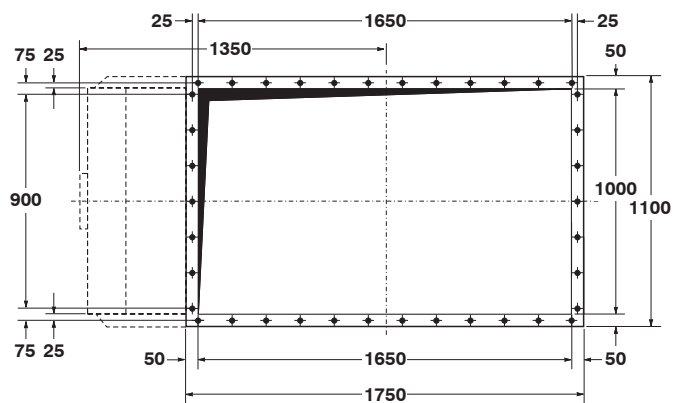

**DLM V21/7, V30/10, V38/12, V45/15, V52/17 AND V60/20**

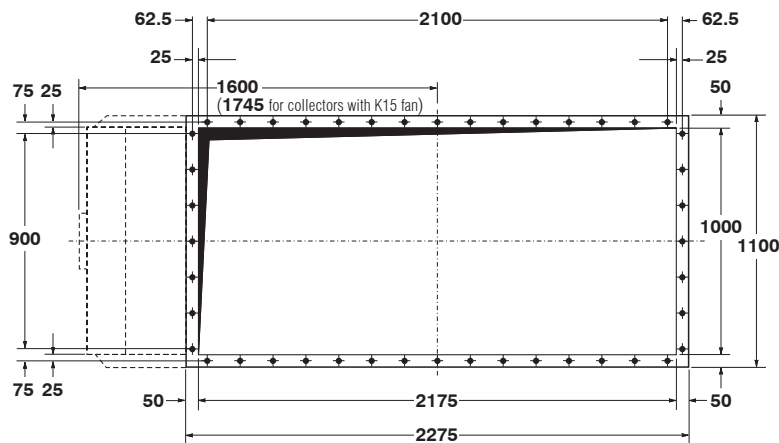

**DLM V50/12, V60/15, V70/17 AND V80/20**

**APERTURE AND MOUNTING FLANGE DETAILS FOR TYPES B, W, H AND F COLLECTORS**

All bolt holes  $\varnothing 12$  mm for M10 set screws. Pitch centres: 150 mm.

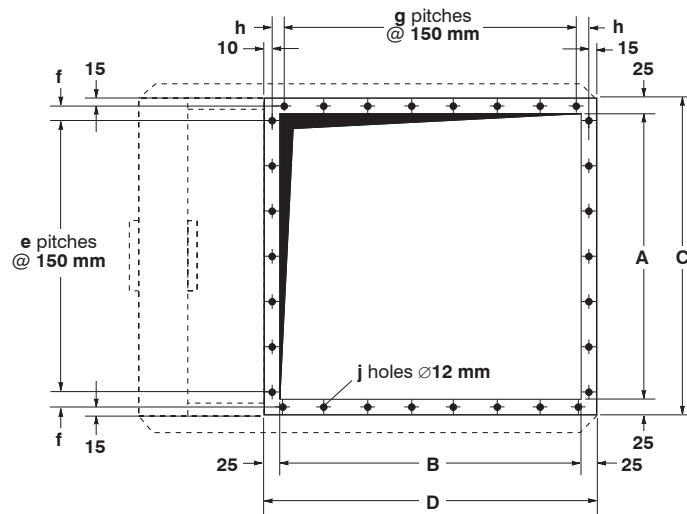

**EXIT HEADER MOUNTING FLANGE DETAILS**

Mounting flange for DLM V14/7B, V20/10B, V25/12B, V30/15B, V35/17 and V40/20 illustrated.

DLM type	A	B	C	D	e	f	g	h	j
V3/7B and V5/12B	378 mm	550 mm	428 mm	600 mm	2	49 mm	3	62.5 mm	14
V4/7B, V6/10B, V7.5/12B and V9/15B	554 mm	550 mm	604 mm	600 mm	3	62 mm	3	62.5 mm	16
V7/7B, V10/10B, V13/12B and V15/15B	954 mm	550 mm	1004 mm	600 mm	6	37 mm	3	62.5 mm	22
V8/7B, V12/10B, V15/12B and V18/15B	554 mm	1075 mm	604 mm	1125 mm	3	62 mm	7	25 mm	24
V14/7B, V20/10B, V25/12B, V30/15B, V35/17 and V40/20	954 mm	1075 mm	1004 mm	1125 mm	6	37 mm	7	25 mm	30
V21/7B, V30/10B, V38/12B, V45/15B, V52/17 and V60/20	954 mm	1675 mm	1004 mm	1725 mm	6	37 mm	11	25 mm	38
V50/12B, V60/15B, V70/17 and V80/20	954 mm	2200 mm	1004 mm	2250 mm	6	37 mm	14	62.5 mm	44

**ELECTRICAL REQUIREMENTS**

- Collectors up to DLM V20/10\*:** 2-, 3- or 5-way controller
- Collectors from DLM V20/10\* upwards:** 10-way controller
- Controller voltage input:** AC version: 105-120V, 200-240V, (±10%)  
DC version: 24V
- Fan motor (if fitted):** To suit local voltage

\* The DLM V20/10 can be supplied with either 5- or 10-way controller

**DESIGN LIMITS (standard equipment)**

- Temperature range** (alternatives according to type of sealer used): (1) -10° to +60°C; (2) -10° to +200°C (not type F)
- Pressure limits:** (a) Types B, W and H: -400 mmW.G. (For positive pressures please refer to Donaldson)  
(b) Type S: -3000 mmW.G. (For positive pressures please refer to Donaldson)  
(c) Type F: as fan performance curves from shut-off to operating pressure
- Dimension tolerances:** ±5 mm on main dimensions; ±2 mm on detail dimensions

Equipment is available suitable for use in a potentially explosive atmosphere (Directive 94/9/EC) satisfying the requirements for group II category 2G or 2D and 3G or 3D T135°C

**Dalamic Insertable Dust Collectors – Series DLM V**

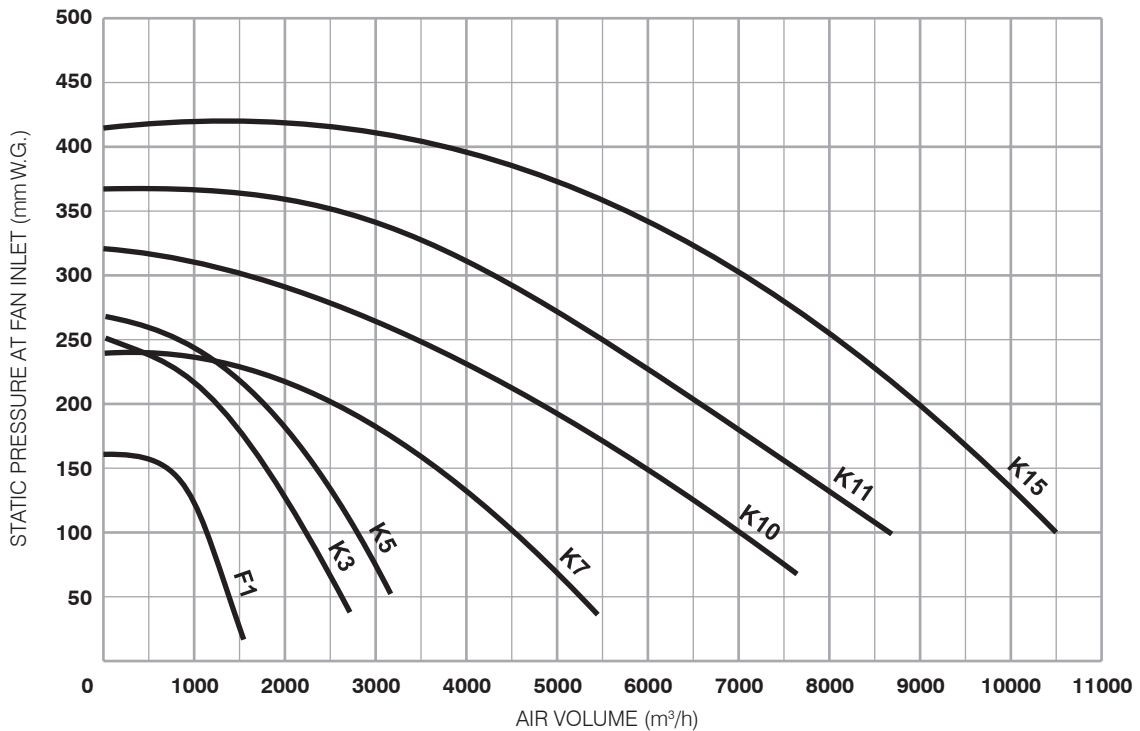

**FAN PERFORMANCE CURVES**

**FAN SELECTION**

To select the most suitable fan for a given application:

- 1 Determine the air volume (m³/h) needed to give effective venting and dust control.
- 2 Estimate pressure or suction (mm W.G.) in the housing in which the dust collector is inserted.
- 3 Assess the operational pressure drop (mm W.G.) across the clean side and dirty side of the filtering elements – usually between 25 to 100 mm W.G.
- 4 The sum of 2 and 3 gives the pressure (mm W.G.) required for fan selection purposes.
- 5 Consult graph for fan performances available.

**NOISE LEVELS**

Machinery noise levels are an important consideration in the design and selection of new equipment. Several EC Directives and National Laws/Regulations adopting these directives make reference to airborne noise emissions. Actions that employers are required to comply with if employees are subjected to a daily personal noise exposure  $L_{ep,d}$  of 80 dB(A) or more are also specified.

**WEIGHTED SOUND PRESSURE LEVELS**

All readings were taken in normal industrial areas, i.e. semi-reverberant surroundings, with local equipment silent. Measurements were taken at maximum air flow conditions at 1.0 metre radius from the equipment housing and 1.6 metres above base level, using a precision sound level meter and octave filter.

	<b>F1</b> (0.75 kW)	<b>K3</b> (1.5 kW)	<b>K5</b> (2.2 kW)	<b>K7</b> (3.0 kW)	<b>K10</b> (5.5 kW)	<b>K11</b> (7.5 kW)	<b>K15</b> (11.0 kW)
With acoustic diffuser	76 dB(A)	73 dB(A)	74 dB(A)	76 dB(A)	79 dB(A)*	84 dB(A)	85 dB(A)
Without acoustic diffuser	91 dB(A)	89 dB(A)	92 dB(A)	93 dB(A)	94 dB(A)	97 dB(A)	99 dB(A)

Noise levels of installed equipment may vary due to site conditions. \*Estimated data.



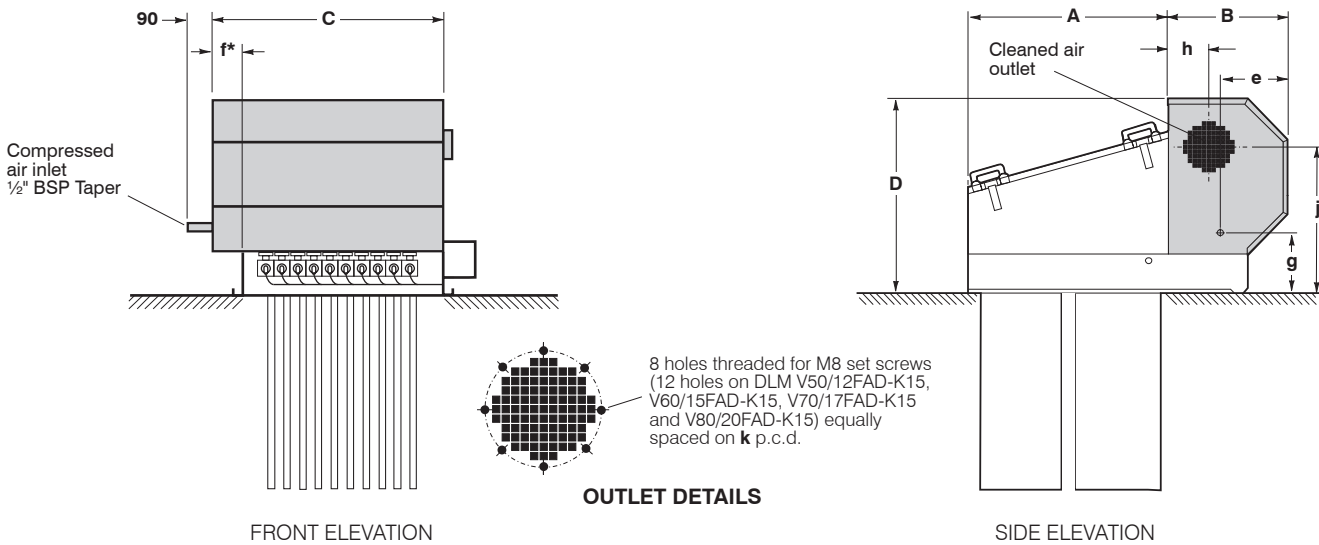

**DALAMATIC INSERTABLE ACOUSTIC DIFFUSER DETAILS**

Suitable for inside and outside locations.

Nominal clearances for maintenance are as shown on page 4.

\* Note: On models DLM V4/7FAD, V6/10FAD, V7.5/12FAD, V8/7FAD, V9/15FAD, V12/10FAD, V15/12FAD and V18/15FAD the acoustic diffuser overhangs on the left and the controller is on the right (as illustrated). On models DLM V50/12FAD-K15, V60/15FAD-K15, V70/17FAD-K15 and V80/20FAD-K15 the overhang is on the right and the controller is on the left. On all other models there is no overhang and the controller can be fitted on either side. In all cases the compressed air inlet pipe is on the opposite side to the controller.

DLM type	DIMENSIONS in mm										Net weight (acoustic diffuser)
	A	B	C	D	e	f*	g	h	j	k	
V4/7FAD	605	600	740	1100	300	140	295	200	860	310	42 kg
V6/10FAD	605	600	740	1100	300	140	295	200	860	310	42 kg
V7/7FAD	605	600	1010	1100	300	-	295	200	860	310	47 kg
V7.5/12FAD	605	600	740	1100	300	140	295	200	860	310	42 kg
V8/7FAD	1130	690	740	1100	315	140	310	240	860	340	45 kg
V9/15FAD	605	600	740	1100	300	140	295	200	860	310	42 kg
V10/10FAD	605	600	1010	1100	300	-	295	200	860	310	47 kg
V12/10FAD	1130	690	740	1100	315	140	310	240	860	340	45 kg
V13/12FAD	605	600	1010	1100	300	-	295	200	860	310	47 kg
V14/7FAD	1130	690	1010	1100	315	-	310	240	860	340	50 kg
V15/12FAD	1130	690	740	1100	315	140	310	240	860	340	45 kg
V15/15FAD	605	600	1010	1100	300	-	295	200	860	310	47 kg
V18/15FAD	1130	690	740	1100	315	140	310	240	860	340	45 kg
V20/10FAD	1130	690	1010	1100	315	-	310	240	860	340	50 kg
V21/7FAD	1730	810	1010	1190	440	-	310	265	910	390	58 kg
V25/12FAD	1130	690	1010	1100	315	-	310	240	860	340	50 kg
V30/10FAD	1730	810	1010	1190	440	-	310	265	910	390	58 kg
V30/15FAD	1130	690	1010	1100	315	-	310	240	860	340	50 kg
V35/17FAD	1130	690	1010	1100	315	-	310	240	860	340	50 kg
V38/12FAD	1730	810	1010	1190	440	-	310	265	910	390	58 kg
V40/20FAD	1130	690	1010	1100	315	-	310	240	860	340	50 kg
V45/15FAD	1730	810	1010	1190	440	-	310	265	910	390	58 kg
V50/12FAD-K10 V50/12FAD-K11	2255	810	1010	1190	440	-	310	265	910	390	60 kg
V50/12FAD-K15	2255	960	1215	1250	445	215	310	330	895	520	85 kg
V52/17FAD	1730	810	1010	1190	440	-	310	265	910	390	58 kg
V60/15FAD-K10 V60/15FAD-K11	2255	810	1010	1190	440	-	310	265	910	390	60 kg
V60/15FAD-K15	2255	960	1215	1250	445	215	310	330	895	520	85 kg
V60/20FAD	1730	810	1010	1190	440	-	310	265	910	390	58 kg
V70/17FAD-K10 V70/17FAD-K11	2255	810	1010	1190	440	-	310	265	910	390	60 kg
V70/17FAD-K15	2255	960	1215	1250	445	215	310	330	895	520	85 kg
V80/20FAD-K10 V80/20FAD-K11	2255	810	1010	1190	440	-	310	265	910	390	60 kg
V80/20FAD-K15	2255	960	1215	1250	445	215	310	330	895	520	85 kg

**Dalamatic Insertable Dust Collectors – Series DLM V**

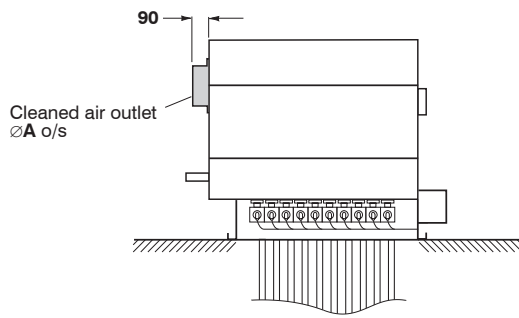

FRONT ELEVATION

**OPTIONAL ACOUSTIC DIFFUSER  
DUCT CONNECTION SPIGOT**

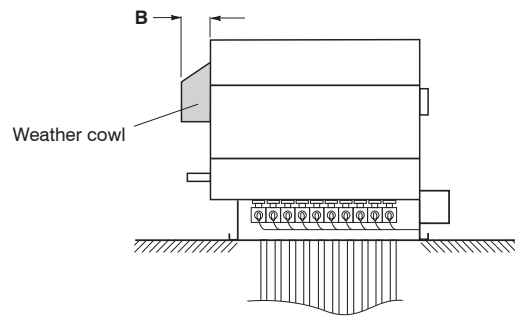

FRONT ELEVATION

**OPTIONAL ACOUSTIC DIFFUSER  
WEATHER COWL**

DLM type	DIMENSIONS in mm	
	A	B
V4/7FAD, V6/10FAD, V7/7FAD, V7.5/12FAD, V9/15FAD, V10/10FAD, V13/12FAD and V15/15FAD	270	172
V8/7FAD, V12/10FAD, V14/7FAD, V15/12FAD, V18/15FAD, V20/10FAD, V25/12FAD, V30/15FAD, V35/17FAD and V40/20FAD	300	196
V21/7FAD, V30/10FAD, V38/12FAD, V45/15FAD, V50/12FAD, V52/17FAD, V60/15FAD, V60/20FAD, V70/17FAD and V80/20FAD	350	240
V50/12FAD-K15, V60/15FAD-K15, V70/17FAD-K15 and V80/20FAD-K15	480	260

COMPRESSED AIR REQUIREMENTS						
DLM type	Working compressed air pressure <sup>a</sup>		Atmospheric air volume – F.A.D. <sup>b</sup>		Pulse duration	
at 25 s intervals <sup>c</sup>						
V3/7 and V5/12	4.1 bar	60 psig	2.6 m <sup>3</sup> /h	1.5 cfm	100 ms	
V4/7, V6/10, V7.5/12 and V9/15	4.1 bar	60 psig	3.3 m <sup>3</sup> /h	1.9 cfm	100 ms	
V7/7, V10/10, V13/12 and V15/15	4.1 bar	60 psig	4.0 m <sup>3</sup> /h	2.4 cfm	100 ms	
V8/7, V12/10, V15/12 and V18/15	5.2 bar	75 psig	6.0 m <sup>3</sup> /h	3.6 cfm	100 ms	
V14/7 and V20/10 (5 valve)	5.2 bar	75 psig	7.2 m <sup>3</sup> /h	4.2 cfm	100 ms	
at 12 s intervals <sup>c</sup>						
V20/10 (10 valve)	4.1 bar	60 psig	6.1 m <sup>3</sup> /h	3.6 cfm	60 ms	
V21/7 and V30/10	4.5 bar	65 psig	7.8 m <sup>3</sup> /h	4.6 cfm	60 ms	
V25/12 and V30/15	4.1 bar	60 psig	7.4 m <sup>3</sup> /h	4.3 cfm	60 ms	
V35/17 and V40/20	4.5 bar	65 psig	8.7 m <sup>3</sup> /h	5.1 cfm	100 ms	
V38/12 and V45/15	4.5 bar	65 psig	9.5 m <sup>3</sup> /h	5.6 cfm	60 ms	
V50/12 and V60/15	5.2 bar	75 psig	13.7 m <sup>3</sup> /h	8.0 cfm	60 ms	
V52/17 and V60/20	5.2 bar	75 psig	11.2 m <sup>3</sup> /h	6.6 cfm	100 ms	
V70/17 and V80/20	6.2 bar	90 psig	16.1 m <sup>3</sup> /h	9.5 cfm	100 ms	

<sup>a</sup>Normal operating pressure    <sup>b</sup>Recommended atmospheric air volume of clean, dry compressed air  
<sup>c</sup>Recommended initial settings; these may be varied with experience

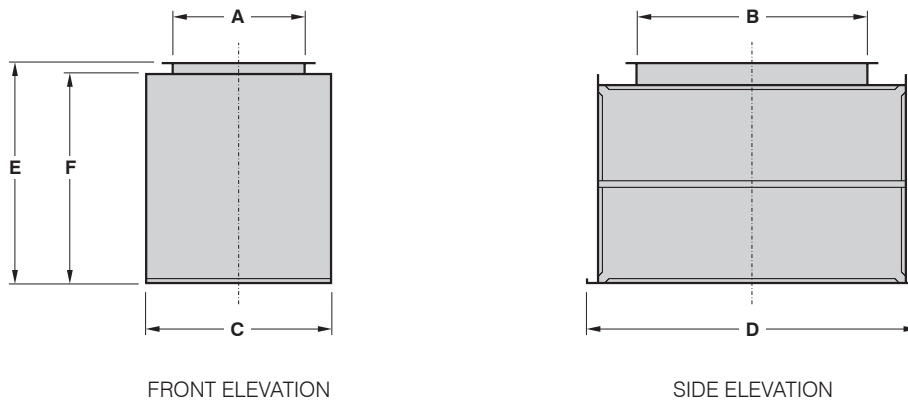

**VERTICAL HOUSING ASSEMBLY**

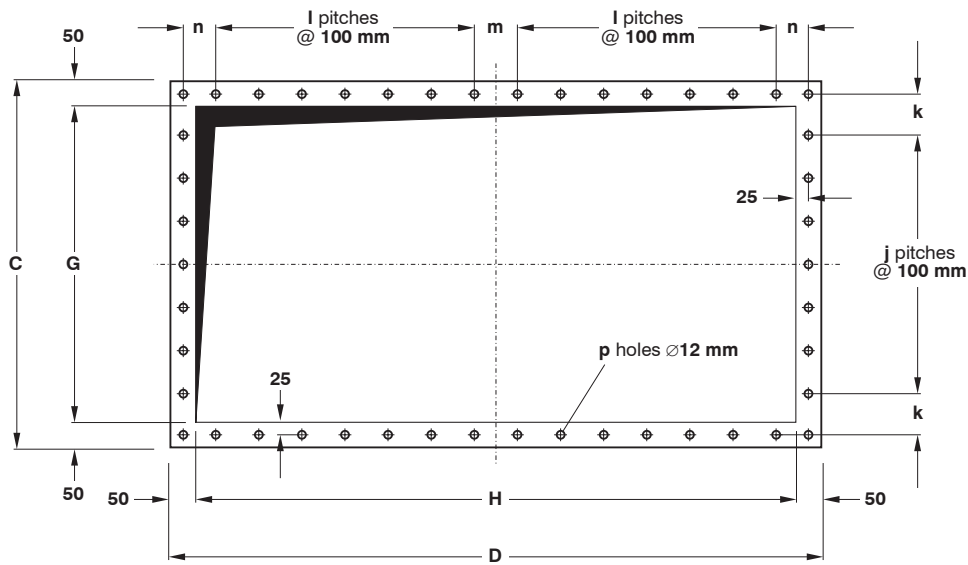

**VERTICAL HOUSING BASE FLANGE**

DLM type	A	B	C	D	E	F	G	H	j	k	l	m	n	p	Net weight (approx.)
V4/7 and V6/10	600 mm	525 mm	840 mm	875 mm	1000 mm	950 mm	740 mm	775 mm	6	95 mm	3	100 mm	62.5 mm	34	120 kg
V7/7 and V10/10	1000 mm	525 mm	1200 mm	875 mm	1000 mm	950 mm	1100 mm	775 mm	10	75 mm	3	100 mm	62.5 mm	42	140 kg
V7.5/12 and V9/15	600 mm	525 mm	1050 mm	1000 mm	1500 mm	1450 mm	950 mm	900 mm	10	0 mm	4	0 mm	75 mm	40	185 kg
V8/7 and V12/10	600 mm	1050 mm	840 mm	1500 mm	1000 mm	950 mm	740 mm	1400 mm	6	95 mm	6	100 mm	75 mm	46	160 kg
V13/12 and V15/15	1000 mm	525 mm	1200 mm	1200 mm	1500 mm	1450 mm	1100 mm	1100 mm	10	75 mm	4	100 mm	125 mm	46	235 kg
V14/7 and V20/10	1000 mm	1050 mm	1400 mm	1500 mm	1000 mm	950 mm	1300 mm	1400 mm	12	75 mm	6	100 mm	75 mm	58	195 kg
V15/12 and V18/15	600 mm	1050 mm	1050 mm	1500 mm	1500 mm	1450 mm	950 mm	1400 mm	10	0 mm	6	100 mm	75 mm	50	240 kg
V21/7 and V30/10	1000 mm	1650 mm	1400 mm	2300 mm	1000 mm	950 mm	1300 mm	2200 mm	12	75 mm	9	200 mm	125 mm	70	275 kg
V25/12 and V30/15	1000 mm	1050 mm	1400 mm	1900 mm	1500 mm	1450 mm	1300 mm	1800 mm	12	75 mm	8	100 mm	75 mm	66	325 kg
V38/12 and V45/15	1000 mm	1650 mm	1400 mm	2800 mm	1500 mm	1450 mm	1300 mm	2700 mm	12	75 mm	13	0 mm	75 mm	84	430 kg
V50/12 and V60/15	1000 mm	2175 mm	1400 mm	3700 mm	1500 mm	1450 mm	1300 mm	3600 mm	12	75 mm	17	100 mm	75 mm	102	520 kg

**OPTIONAL VERTICAL HOUSING DETAILS**

Vertical housing for DLM V8/7 or V12/10 illustrated.

**Dalamatic Insertable Dust Collectors – Series DLM V**

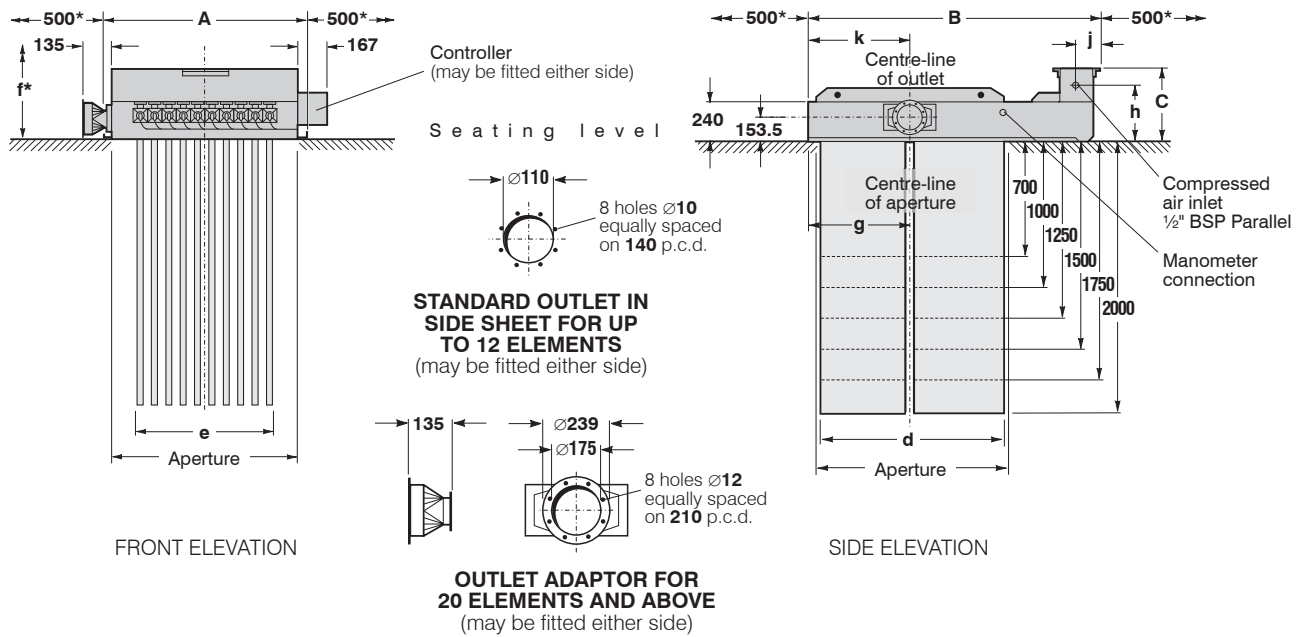

\* Nominal clearances for maintenance  
 Where space is restricted please consult with Donaldson. Clearance of at least 150 mm to be left on all sides of the filter elements.

**DALAMATIC S TYPE INSERTABLE DUST COLLECTOR**

Model DLM V40/20S illustrated, broken lines representing models DLM V14/7S, DLM V20/10S, DLM V25/12S, DLM V30/15S and DLM V35/17S. Suitable for inside and outside locations.

DLM type	Filtration area	Number of elements	DIMENSIONS in mm											Net weight (approx.)
			A	B	C	d	e	f*	g	h	j	k		
V3/7S	3 m <sup>2</sup>	4	524	1015	395	480	294	850	310	315	115	310	110 kg	
V4/7S	4 m <sup>2</sup>	6	700	1015	395	480	470	850	310	315	115	310	140 kg	
V5/12S	5 m <sup>2</sup>	4	524	1015	395	480	294	1400	310	315	115	310	116 kg	
V6/10S	6 m <sup>2</sup>	6	700	1015	395	480	470	1150	310	315	115	310	150 kg	
V7/7S	7 m <sup>2</sup>	10	1100	1015	395	480	820	850	310	315	115	310	205 kg	
V7.5/12S	7.5 m <sup>2</sup>	6	700	1015	395	480	470	1400	310	315	115	310	155 kg	
V8/7S	8 m <sup>2</sup>	12	700	1625	420	1005	470	850	575	330	130	565	220 kg	
V9/15S	9 m <sup>2</sup>	6	700	1015	395	480	470	1650	310	315	115	310	160 kg	
V10/10S	10 m <sup>2</sup>	10	1100	1015	395	480	820	1150	310	315	115	310	225 kg	
V12/10S	12 m <sup>2</sup>	12	700	1625	420	1005	470	1150	575	330	130	565	240 kg	
V13/12S	13 m <sup>2</sup>	10	1100	1015	395	480	820	1400	310	315	115	310	233 kg	
V14/7S	14 m <sup>2</sup>	20	1100	1625	420	1005	820	850	575	330	130	592	370 kg	
V15/12S	15 m <sup>2</sup>	12	700	1625	420	1005	470	1400	575	330	130	565	249 kg	
V15/15S	15 m <sup>2</sup>	10	1100	1015	395	480	820	1650	310	315	115	310	245 kg	
V18/15S	18 m <sup>2</sup>	12	700	1625	420	1005	470	1650	575	330	130	565	265 kg	
V20/10S	20 m <sup>2</sup>	20	1100	1625	420	1005	820	1150	575	330	130	592	405 kg	
V21/7S	21 m <sup>2</sup>	30	1100	2225	420	1605	820	850	875	330	130	742	525 kg	
V25/12S	25 m <sup>2</sup>	20	1100	1625	420	1005	820	1400	575	330	130	592	420 kg	
V30/10S	30 m <sup>2</sup>	30	1100	2225	420	1605	820	1150	875	330	130	742	570 kg	
V30/15S	30 m <sup>2</sup>	20	1100	1625	420	1005	820	1650	575	330	130	592	455 kg	
V35/17S	35 m <sup>2</sup>	20	1100	1625	420	1005	820	1150	575	330	130	592	462 kg	
V38/12S	38 m <sup>2</sup>	30	1100	2225	420	1605	820	1400	875	330	130	742	592 kg	
V40/20S	40 m <sup>2</sup>	20	1100	1625	420	1005	820	1150	575	330	130	592	479 kg	
V45/15S	45 m <sup>2</sup>	30	1100	2225	420	1605	820	1650	875	330	130	742	630 kg	
V50/12S	50 m <sup>2</sup>	40	1100	2747	420	2130	820	1400	1137	330	130	1234	790 kg	
V52/17S	52 m <sup>2</sup>	30	1100	2225	420	1605	820	1650	875	330	130	742	660 kg	
V60/15S	60 m <sup>2</sup>	40	1100	2747	420	2130	820	1650	1137	330	130	1234	820 kg	
V60/20S	60 m <sup>2</sup>	30	1100	2225	420	1605	820	1650	875	330	130	742	685 kg	
V70/17S	70 m <sup>2</sup>	40	1100	2747	420	2130	820	1650	1137	330	130	1234	863 kg	
V80/20S	80 m <sup>2</sup>	40	1100	2747	420	2130	820	1650	1137	330	130	1234	897 kg	

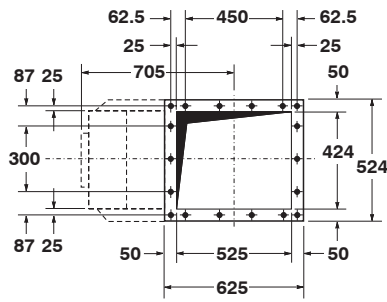

**DLM V3/7 AND V5/12**

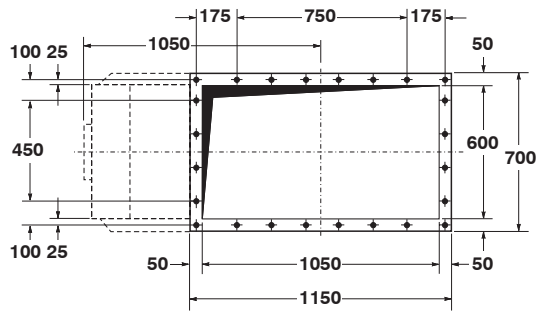

**DLM V8/7, V12/10, V15/12 AND V18/15**

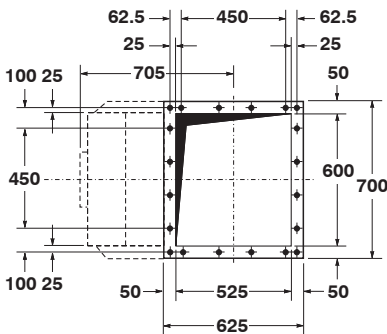

**DLM V4/7, V6/10, V7.5/12 AND V9/15**

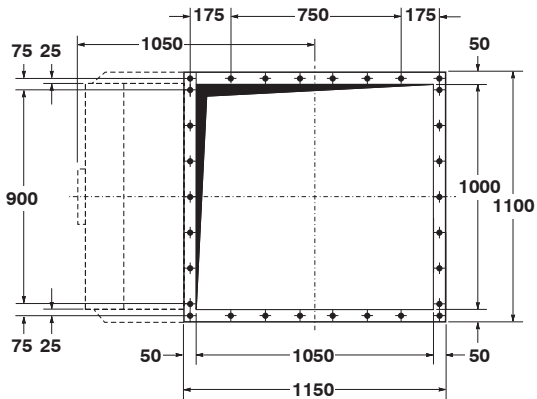

**DLM V14/7, V20/10, V25/12, V30/15, V35/17 AND V40/20**

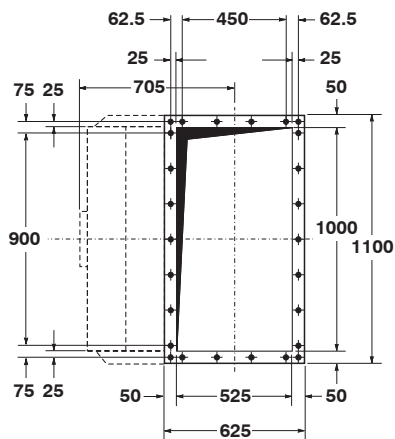

**DLM V7/7, V10/10, V13/12 AND V15/15**

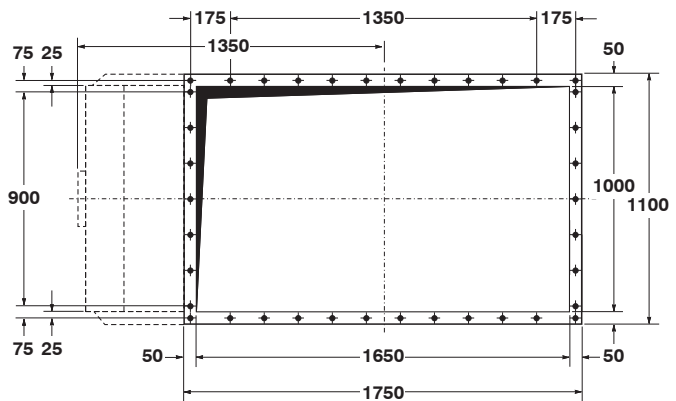

**DLM V21/7, V30/10, V38/12, V45/15, V52/17 AND V60/20**

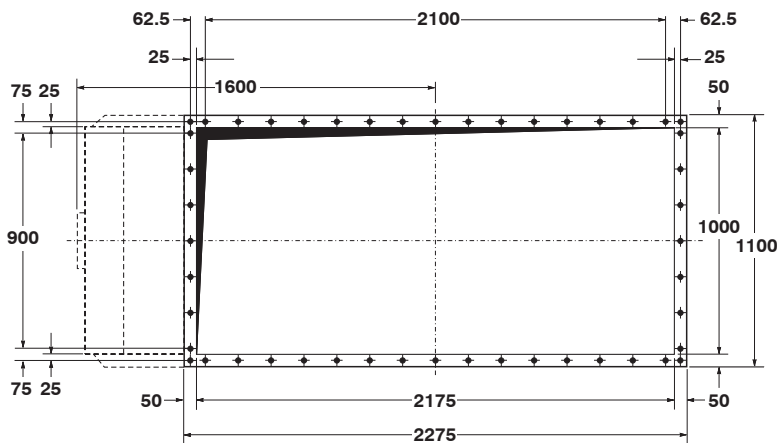

**DLM V50/12, V60/15, V70/17 AND V80/20**

**APERTURE AND MOUNTING FLANGE DETAILS FOR TYPE S COLLECTOR**

All bolt holes  $\varnothing 12$  mm for M10 set screws. Pitch centres: 150 mm.

---

**Dalamatic Insertable Dust Collectors – Series DLM V**



[www.donaldson.com](http://www.donaldson.com)

Humberstone Lane  
Thurmaston  
Leicester LE4 8HP  
England

Tel +44 (0)116 269 6161  
Fax +44 (0)116 269 3028

Email: [IAF-uk@donaldson.com](mailto:IAF-uk@donaldson.com)

Research Park Building No. 1303  
Interleuvenlaan 1  
B-3001 Leuven (Heverlee)  
Belgium

Tel +32 (0)16 383 970  
Fax +32 (0)16 383 938

Email: [IAF-europe@donaldson.com](mailto:IAF-europe@donaldson.com)