

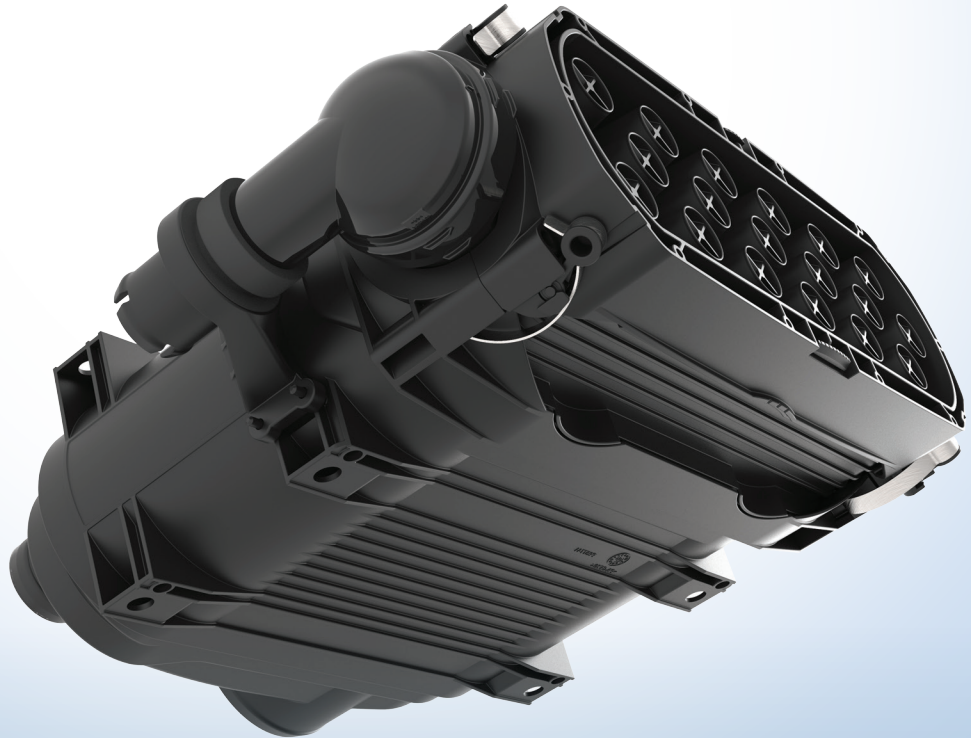

DONALDSON DELIVERS

# Next Generation Front Service Engine Air Cleaner

**PowerCore® Edge™**





## Bringing top filtration technology to the next level.

### Easy front servicing

Robust snap fit latches for fast and easy front service access

### Improved pre-cleaner maintenance

Designed to easily separate into two pieces to allow for fast and easy cleaning

### PowerCore filter element

High-efficiency media technology



### Next generation pre-cleaner tubes

Bringing greater pre-cleaner efficiency for longer filter life

### Permanent scavenge line connection on the body (Optional)

#### Benefits:

- + Easy access to the filter servicing
- + Reduced overall service time
- + 100% secured scavenge connection

### Unique Seal Design

Withstands temperatures up to 100°C

### Filter Minder integrated visual indicator or wireless technology (Optional)

Choose integrated visual indicator or real-time wireless information

### Flexible mounting options

Allows for a range installation locations of attachment configurations

# PowerCore Edge

## Space-saving Engine Front Service Air Cleaners

Compact high-efficiency engine air cleaners for use in heavy dust environments. PowerCore Edge air cleaners are designed to fit into very tight spaces, withstand higher temperatures and offer easier servicing than previous generations of air cleaners.

### PowerCore Edge 8"

- + 5-8m<sup>3</sup>/min
- + 1" **shorter** in length compared to PowerCore PSD 8"

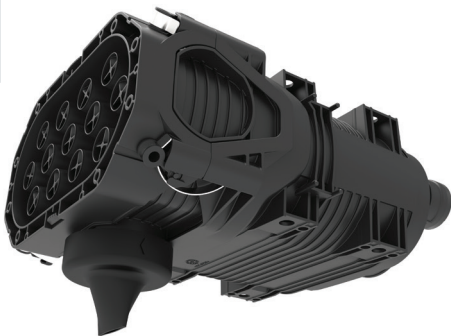

AC Model	Size	New AC	Main Element	Safety Element
PFD, H, Vac	8"	D080186	P958647	P957712
PFD, V, Vac		D080187		
PFD, V, Scav		D080188		

### PowerCore Edge 9"

- + 7-11m<sup>3</sup>/min
- + 25% size **reduction** compared to PowerCore PSD 9"



AC Model	Size	New AC	Main Element	Safety Element
PFD, H, Vac	9"	D090357	P958648	P957732
PFD, V, Vac		D090358		
PFD, V, Scav		D090359		

- + **Unique filter element sealing** technology
- + **Serviceable** pre-cleaner
- + Improved **water tightness**
- + Increased **temperature** range (up to 100°C)
- + **Reduced** filter servicing space
- + **Pre-cleaning flexibility** with optional scavenge on body
- + **Advanced Filter Data** – Real-time filter data with Filter Minder wireless or integrated visual indicator
- + **Mounting flexibility** – Horizontal/Vertical

# Finding your Donaldson filter online has never been easier.

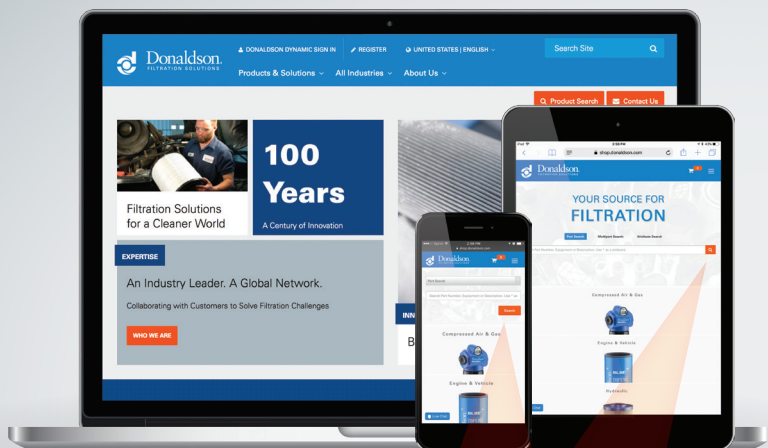

## DISCOVER

Looking for the right filter? Go online to Donaldson.com. Our long-lasting filters deliver quality, performance, and a warranty you can really trust.



[donaldson.com](https://www.donaldson.com)

## DECIDE

Are you a Donaldson partner?  
Order your Donaldson Filters online.

Are you an equipment owner looking to purchase filters and parts for fleet?  
You can add the right filters to your shopping list and request a quote from one of our partners.



[shop.donaldson.com](https://shop.donaldson.com)

## CONNECT



Stay up to date  
[linkedin.com/company/donaldson/](https://www.linkedin.com/company/donaldson/)



Watch our videos and training tutorials  
[youtube.com/user/donaldsonfilters](https://www.youtube.com/user/donaldsonfilters)



Donaldson Europe BV.  
Interleuvenlaan 1  
3001 Leuven  
Belgium  
[www.donaldson.com](https://www.donaldson.com)

Brochure No. F210018 (11/22)  
© 2022 Donaldson Company, Inc.  
Donaldson Company, Inc. reserves the right to change or discontinue any model or specification at any time and without notice.